

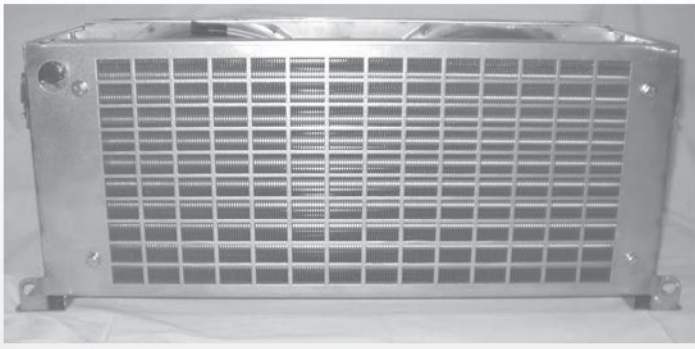

Features

- Heavy-duty stainless steel construction
- No top openings to reduce dirt contamination
- Large coil to keep head pressures low in high ambient conditions
- Horizontal motors for optimal bearing life
- Can be used with evaporators up to 22,000 BTU/hr



Suggested Applications



Recommended Bergstrom Electrified System



TPR6

Technical Specifications

Model	TCR6 12V	TCR6 24V
Voltage	12V	24V
Capacity	For use up to 22,000 BTU/hr (6,4 kW)	For use up to 22,000 BTU/hr (6,4 kW)
Maximum air flow	2,400 SCFM (4,078 m³/hr)	2,400 SCFM (4,078 m³/hr)
Dimensions (L x W x H)	32.56in x 15.21in x 13.18in (827mm x 386mm x 335mm)	32.88in x 12.63in x 13.38in (835mm x 321mm x 340mm)
Weight	40 lb (18,1 kg)	40 lb (18,1 kg)
Mounting Position	Rooftop or Deck	Rooftop or Deck

Unless otherwise stated, performance measurements are conducted in accordance with SAE J638 for heaters and IMACA 200 for evaporators.

Dimensions layout

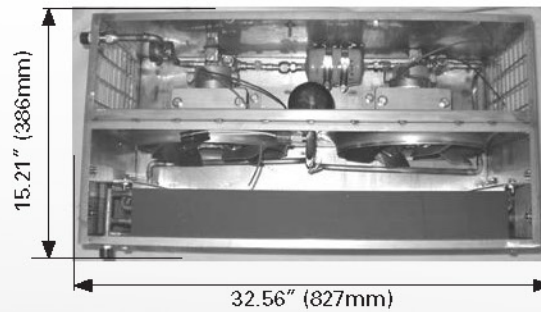

Bergstrom Electrified

Line Drawing

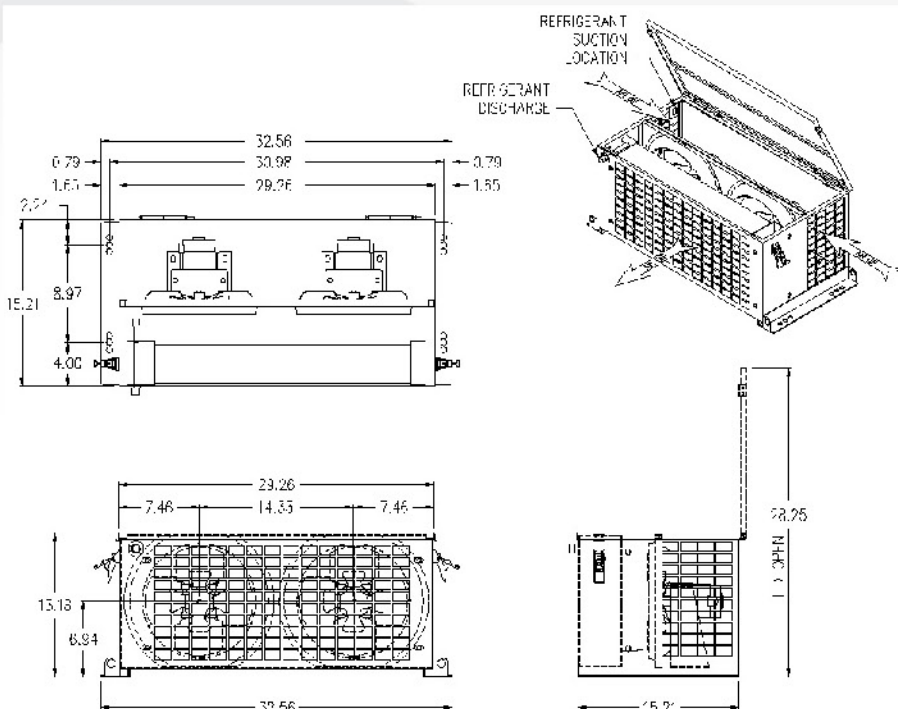

When placing an order please contact your sales representative to review your order to ensure the proper system has been identified for your vehicle application.

Availability of the products shown in this catalog is subject to change without notice by Bergstrom, Inc. For the most current product information please visit the Bergstrom Distributor website at <https://parts.shop.bergstrominc.com/>.