

INTEGRAL POWER II

12 V



Instrucciones de Montaje

Mounting Instructions

Instructions de Montage

Montageanweisungen

Istruzioni di Montaggio

ES

EN

FR

GE

IT

INTEGRAL POWER II	1003714489
Documento	1003714493



Lea atentamente este documento antes de instalar el producto. Conserve este documento para futuras consultas. La documentación original ha sido escrita en español, por lo que el resto de idiomas son traducciones.

Tiene a su disposición todos los manuales del producto en sus versiones digital (PDF) en <https://www.bergstromspain.com/>

Cualquier operación de venta o de garantía está sometida a nuestras condiciones generales de venta en su versión más actualizada, publicada en nuestra página web <https://www.bergstromspain.com/>

Explicación de símbolos



- **Advertencia:** Aviso de seguridad que informa sobre una situación, que de no evitarse, puede provocar lesiones graves o la muerte.



- **Peligro:** Riesgo de corte. Señala una situación que podría provocar un corte.



- **Peligro:** Riesgo de electrocución. Señala una situación que podría provocar una electrocución.



- **Aviso:** Aviso de seguridad que informa sobre una situación, que de no evitarse, puede provocar daños al equipo o a otros materiales.



- **Información:** Información adicional sobre la instalación o el manejo del producto.



- **Frágil:** Indica una situación en la que se debe operar con cuidado para no causar daños al equipo y a otros materiales.



Explicación de responsabilidades

- **Dirna Bergstrom** declina toda responsabilidad ante los daños ocasionados en los siguientes casos:

- Daños en el producto debido a influencias mecánicas y sobretensiones.
- Modificaciones realizadas en el equipo sin el consentimiento expreso del fabricante.
- Utilización del equipo para fines no descritos en este documento.
- Una inadecuada manipulación o instalación del equipo.

- Queda prohibida la manipulación de los circuitos de gas refrigerante sin autorización expresa del fabricante.



Advertencias durante el montaje

- La instalación, reparación y mantenimiento de este equipo de aire acondicionado solo puede ser realizada por aquel personal técnico que posea una formación suficiente en aire acondicionado para vehículos, posibles peligros y normas aplicables.
- Leer detenidamente las instrucciones de montaje antes de iniciar la instalación del equipo. Durante la instalación, seguir al pie de la letra las instrucciones indicadas.
- Al instalar el equipo de aire acondicionado en el techo se debe proteger la parte superior de la cabina con un paño o manta protectora para evitar posibles arañazos. Al instalar **INTEGRAL POWER** en el techo hay que tener en cuenta que, normalmente, las cabinas que vienen provistas de escotilla, tienen una estructura suficiente para soportar el peso del equipo. Sin embargo, cuando no ocurra así y sea necesario realizar corte en el techo o incluso si en el caso de llevar escotilla el material no es lo suficientemente resistente (caso de techo de fibra, plástico, etc...) es el instalador el que debe decidir, **bajo su responsabilidad**, sobre la necesidad de reforzar el techo para evitar posibles deformaciones, roturas, entradas de agua, etc... habilitando los medios para que esto no ocurra.
- Desconectar la llave de contacto antes de iniciar la instalación del equipo.
- Desconectar la batería del vehículo antes de iniciar la instalación del equipo.
- Instale **INTEGRAL POWER** de forma segura para evitar caídas.
- Utilizar las herramientas adecuadas para cada operación.
- Durante la instalación, asegurar la conexión de los componentes eléctricos, verificando su encaje correcto.
- Si en la instalación del equipo los cableados atraviesan paredes con bordes afilados, utilice conductos o guías para evitar que los cables se dañen.
- Si durante la instalación el equipo se inclina, o la cabina se abate con el equipo instalado sobre ella, deberá esperarse un mínimo de 60 minutos, desde que el equipo quede horizontal, antes de ponerlo en marcha.
- Equipo precargado con gas refrigerante r-134a.



- **Aviso importante:** Cualquier modificación de los sistemas ROPS / FOPS, como soldar o perforar agujeros en partes estructurales, afectará la capacidad de ROPS / FOPS para proporcionar la protección requerida. La instalación de este producto puede afectar los sistemas ROPS / FOPS.

Póngase en contacto con su distribuidor autorizado para verificar la compatibilidad antes de realizar modificaciones o reparaciones. De lo contrario, puede anular la certificación ROPS / FOPS. El fabricante del aire acondicionado de techo no asume responsabilidad alguna.



Herramientas necesarias para el montaje

- Juego de llaves Torx.
- Juego de llaves Allen.
- Llave fija 10.
- Tijeras.
- Flexómetro.
- Juego de carraca - boca Ø 10.
- Destornillador estrella / plano.
- Sierra circular Ø 35.
- Taladro - boca Ø 7.
- Sierra vaivén.



Documentación relacionada

- Guía rápida: 1002455105
- Manual de usuario: 1002192411
- Listado de recambios: 1003714494
- Diagnóstico de averías: 1002192414

Dirna Bergstrom declara que el equipo **INTEGRAL POWER** cumple con los requerimientos de las siguientes Directivas CE y que se han aplicado las normas y especificaciones técnicas armonizadas enumeradas a continuación:

- Directiva CE 2014/53/EU
- Directiva CE 2011/65/EU
- Directiva CE 2014/30/EU



Importante: El equipo **Integral Power II** está dotado con 4 cartelas soldadas en los laterales de su base para facilitar su alzado seguro mediante un equipo mecánico de elevación.

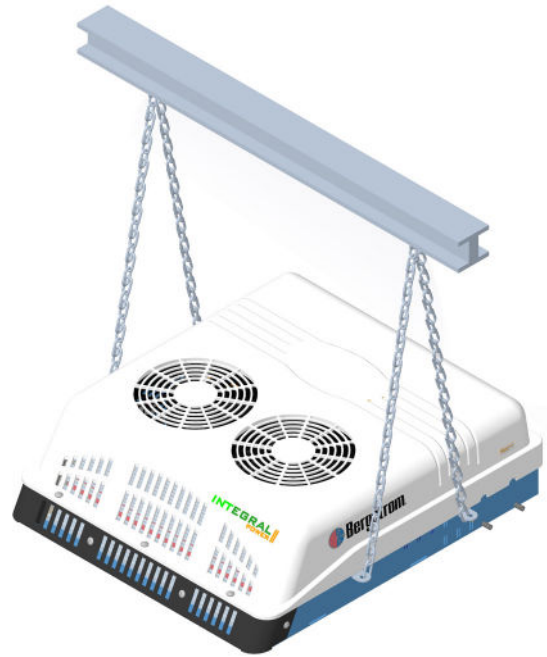
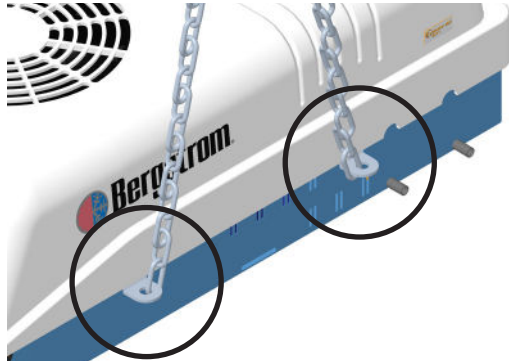

1 Posicionar el equipo **Integral Power II** sobre el techo, teniendo en cuenta que la posición final debe corresponder con el frente suministrado procurando que quede sobre superficie plana.

2 Una vez definida la posición, quitar la carcasa y marcar (6) taladros (Y) seguidamente hacer coincidir los (4) taladros de la plantilla con (4) taladros traseros del techo (figura 3).

Tener en cuenta la flecha que indica el sentido de la marcha.

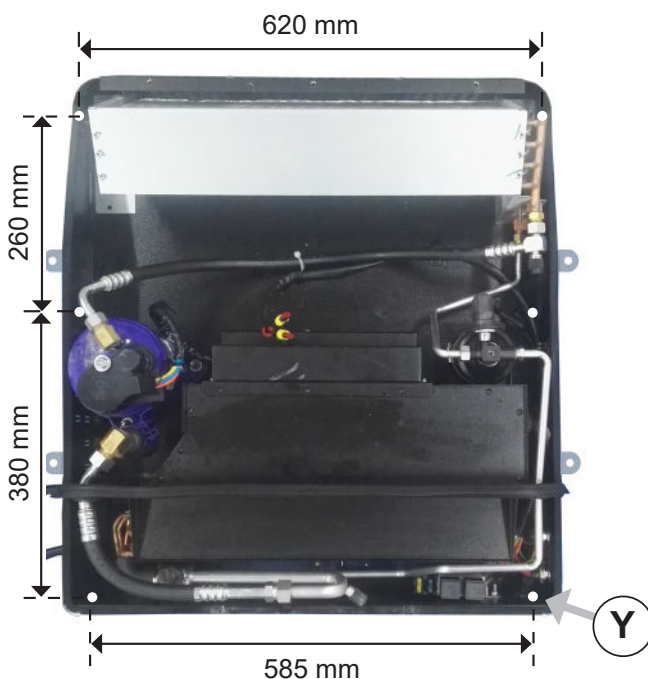
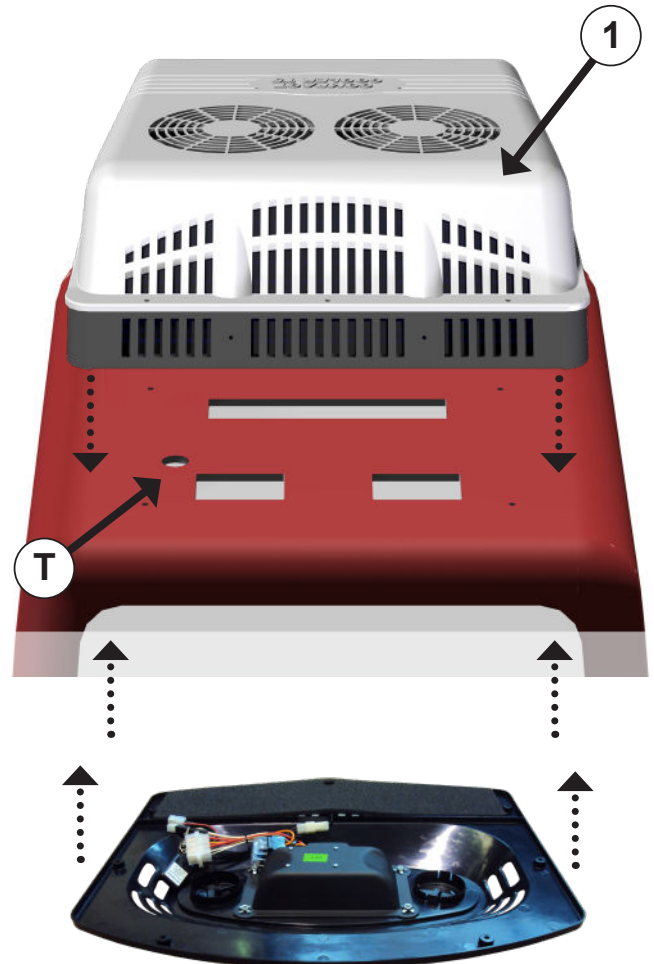

3 Marcar los cortes y taladros y proceder a realizarlos (proteger los cantos cortados con antioxidante).

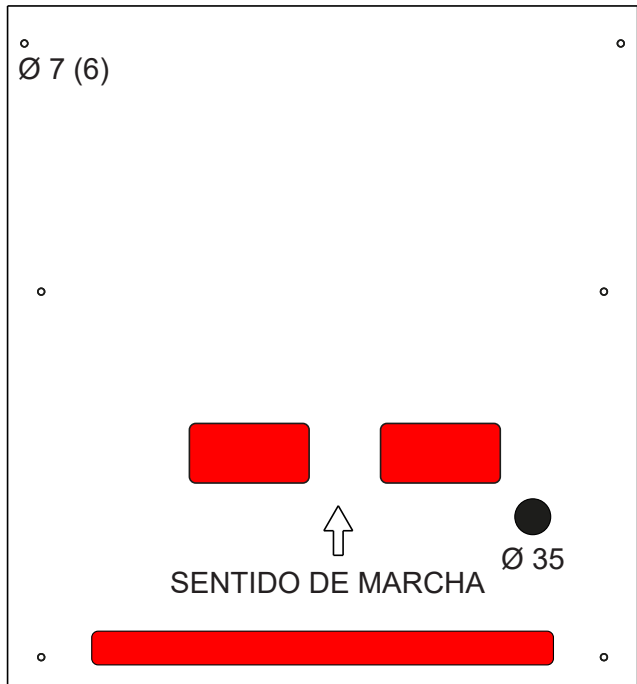

4 Colocar junta cierre, juntas laterales y junta frontal en la parte interior del compacto como se muestra.

a	Junta cierre
b	Juntas laterales
c	Junta frontal

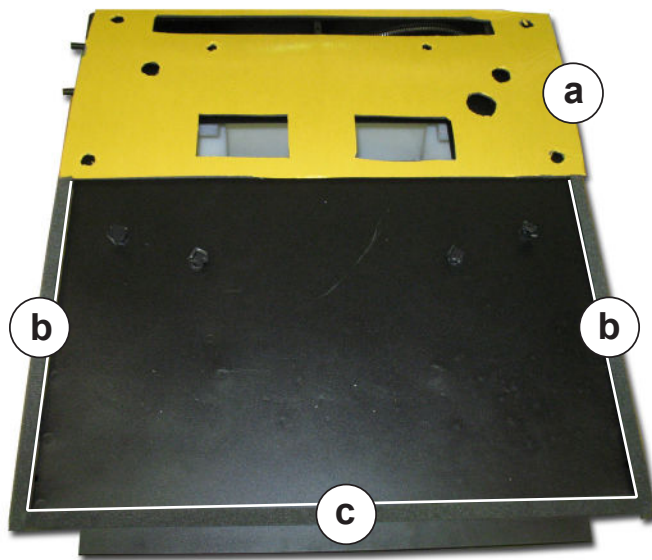

5 Pasar cableado por el traladro (T) realizado en el techo para ello (figura 1). Colocar Integral Power (A) con (6) casquillos de 13 mm, arandelas de goma y (6) tornillos M6/100x40 (B) y tuercas M6/100.

 **Importante:** Asegurar estanqueidad del conjunto al techo para impedir posibles entradas de agua.

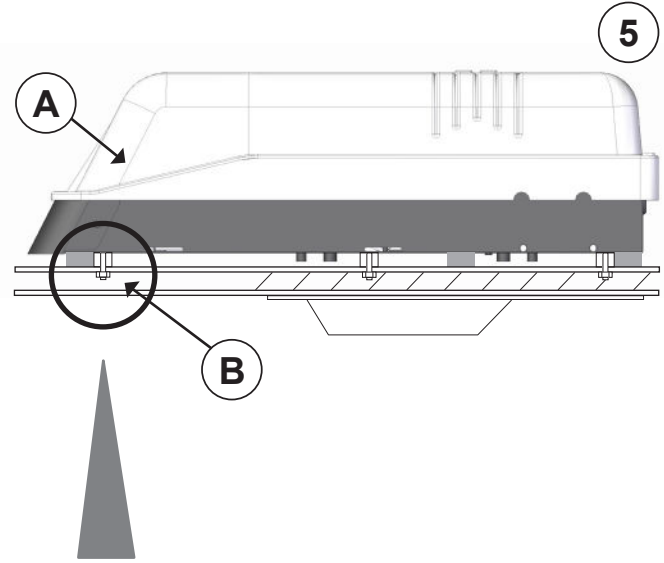

6a Colocar arandelas de goma para evitar paso de agua.

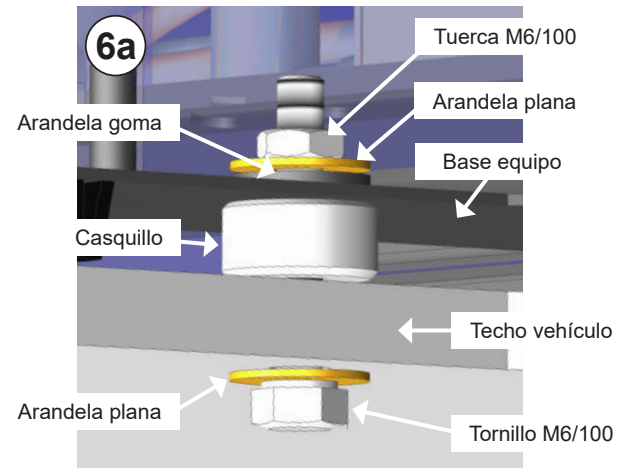

6b

Colocar tubos PVC Ø 9 x Ø 13 suministrados en el equipo según necesidad de longitud.



Atención: Colocar válvulas de drenaje al final de los tubos de PVC para facilitar el drenaje de agua.

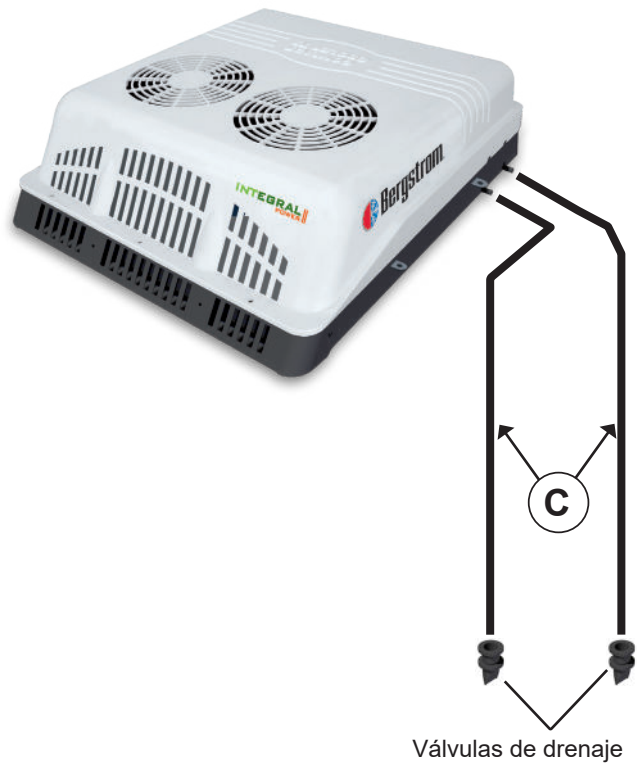

Cableado de conexión a alternador o bajo llave de contacto para funcionamiento del equipo con motor en marcha



Atención: El cableado se instalará en todos los vehículos para que el equipo funcione a motor arrancado.

7

Colocar cableado de excitación por el interior o por el exterior del vehículo según convenga y montar frente con tornillos roscachapa suministrados. Conectar interruptores como se indica.

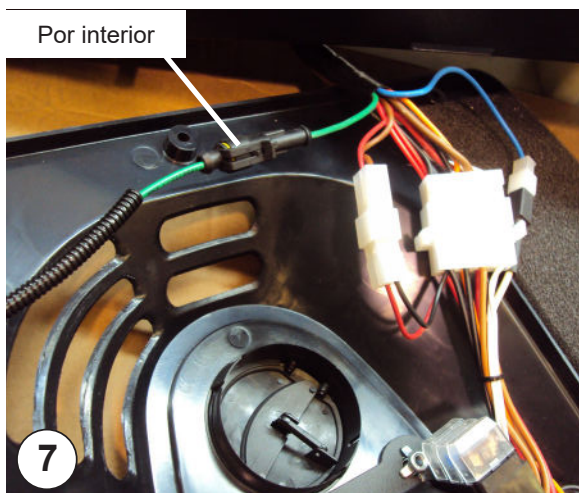
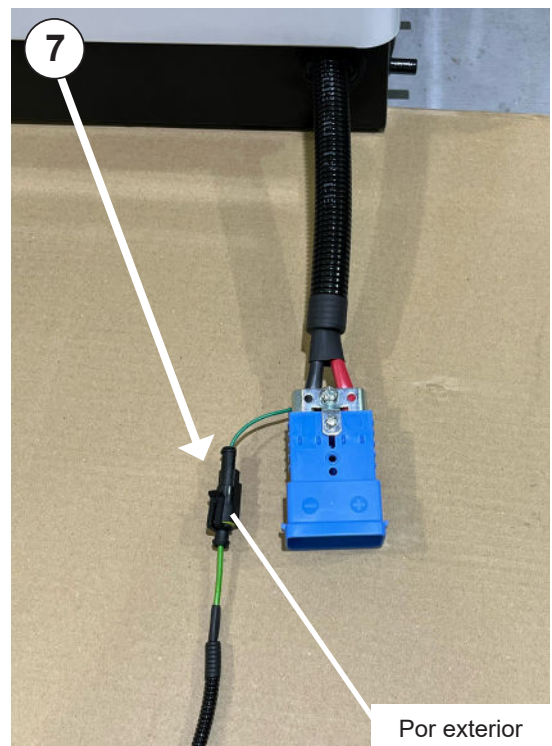

8 Conectar el otro extremo del cableado de excitación suministrado en posición (+) sólo con motor arrancado o a través de (+) llave de contacto.

9 Conectar cable de alimentación en la parte trasera del equipo.
Llevar el cableado de alimentación hasta la batería del vehículo.
Importante: Al conectar los cableados, dejar la distancia adecuada, para evitar su rotura por los movimientos del vehículo.

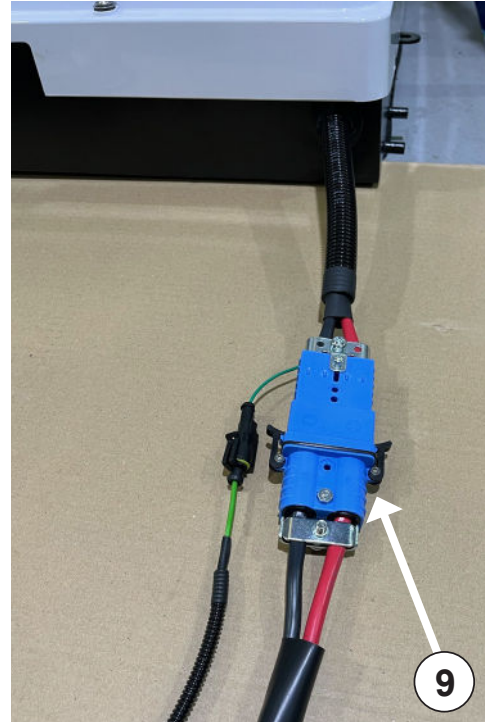

10 Para aquellos vehículos cuya cabina se abata se han incorporado 2 adhesivos de advertencia a modo de recordatorio de la necesidad de desconectar el cableado de alimentación del equipo antes de abatir la cabina.
Situat los adhesivos junto al mecanismo de abatimiento de la cabina y la conexión de los cableados de alimentación.



Atención: Para los vehículos que requieran de una mayor longitud del cableado de alimentación o cuya cabina se abata existe una extensión de cable opcional de 3 metros referencia: 1003713621.



Importante: Para la puesta en marcha consultar el manual de usuario: 1002192411.

Esquema eléctrico

Az	Azul
N	Negro
R	Rojo
V	Verde
B	Blanco
A	Amarillo
Na	Naranja
M	Marrón

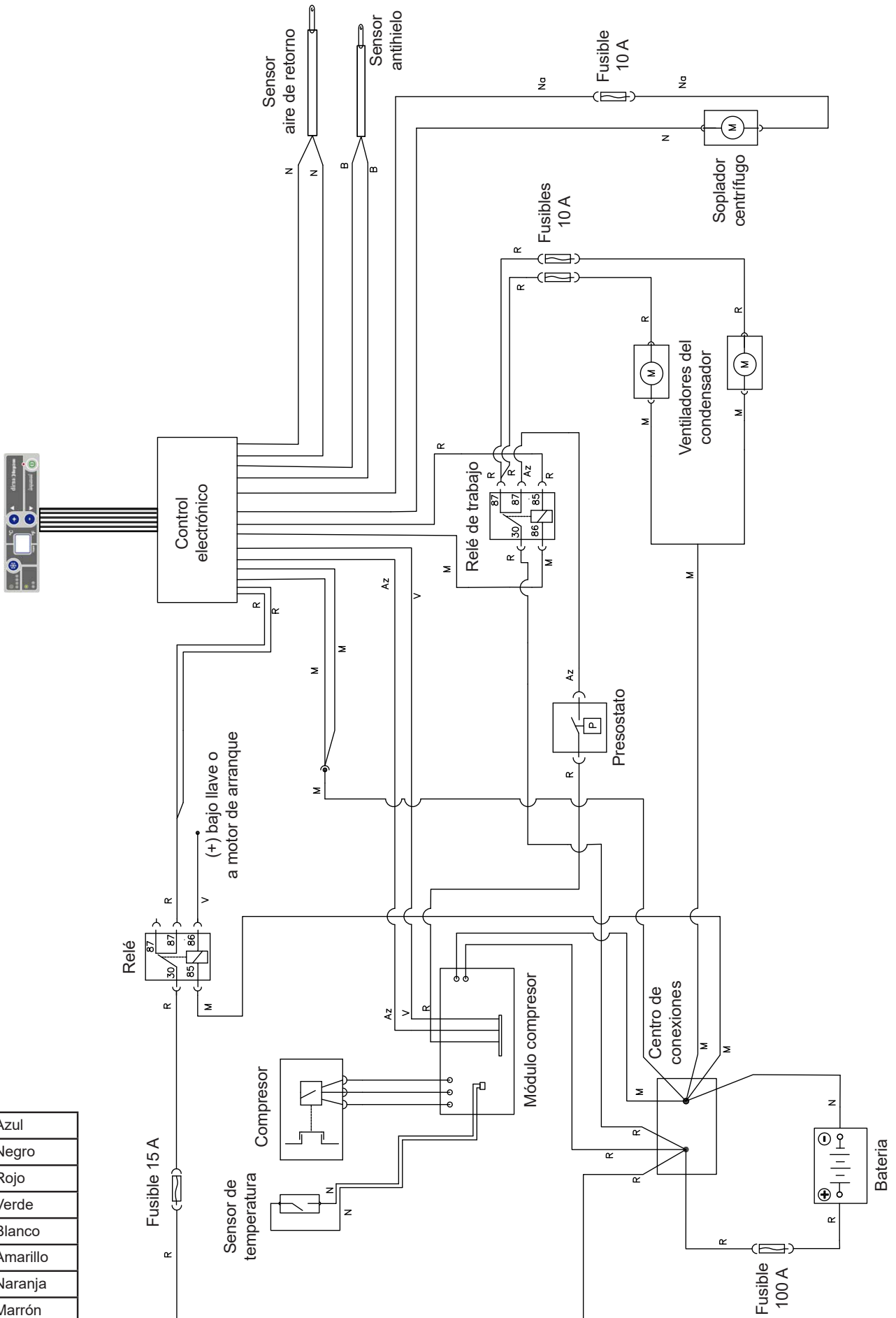



Read this document carefully before installing the product. Keep this document for future reference. The original documentation was written in Spanish, all other languages are translations.

All product manuals are available in their digital versions (PDF) at

<https://www.bergstromspain.com/>

All sales and warranty transactions are subject to our general conditions of sale in their latest version, published on our website

<https://www.bergstromspain.com/>

Explanation of symbols



- **Warning:** A safety warning indicating a situation which, if not avoided, could result in death or serious injury.



- **Danger:** Cutting risk. Indicates a situation that could lead to cutting.



- **Danger:** Risk of electrocution. Indicates a situation that could lead to electrocution.



- **Caution:** Safety warning informing about a situation, which if not avoided, could result in damage to the unit or other materials.



- **Information:** Additional information on the installation or handling of the product.



- **Fragile:** Indicates a situation in which care must be taken to avoid damage to the unit and other materials.



Explanation of liability

- **Dirna Bergstrom** accepts no responsibility for damage caused in the following cases:

- Damage to the product due to mechanical influences and surges.
- Modifications made to the unit without the manufacturer's express consent.
- Use of the unit for purposes not described in this document.
- Improper handling or installation of the unit.

- It is forbidden to tamper with the refrigerant gas circuits without the manufacturer's express authorisation.



Warnings during assembly

- The installation, repair and maintenance of this air conditioning unit may only be carried out by technical staff with sufficient training in vehicle air conditioning, possible dangers and applicable standards.
 - Read the installation instructions carefully before starting to install the unit. During installation, follow the instructions carefully.
 - When installing air conditioning equipment on roof, the upper cabin part must be protected with a cloth or a protective blanket to avoid possible scratches. When installing **INTEGRAL POWER** on roof, take into account that, normally, cabins equipped with a hatch have a strong enough structure to hold equipment weight. However, if it is not the case and it is necessary to carry out a cut in the roof or, although it has a hatch, the material is not resistant enough (*if roof is made of fibre, plastic, etc...*), it is the installer who will have to decide, under his responsibility, if it is necessary to reinforce the roof to avoid possible deformations, breaks, water entries, etc., habilitating the means required to stop it from occurring.
 - Switch off the ignition key before starting to install the unit.
 - Disconnect the vehicle's battery before starting to install the unit.
 - Install **INTEGRAL POWER** securely to prevent it from falling.
 - Use the appropriate tools for each operation.
 - During installation, ensure the connection of the electrical components, checking that they are fitted correctly.
 - If during installation of the unit the cables pass through walls with sharp edges, use conduits or guides to prevent damage to the cables.
 - If during installation the unit is tilted, or the cab is tilted with the unit installed on top, you must wait at least 60 minutes after placing the unit in horizontal position before it is started.
 - Unit pre-charged with r-134a refrigerant gas.
- **Important:** Any modification to ROPS/FOPS, such as welding or drilling holes in the structural members for mounting brackets, will affect the ROPS/FOPS capability to provide the required protection. Installing this product may affect ROPS/FOPS systems.



Contact your authorized dealer to check compatibility before making any modifications or repairs. Failure to do so may void the ROPS/FOPS certification. The manufacturer of the roof air conditioner assumes no liability whatsoever.



Tools required for assembly

- Torx wrenches set.
- Allen wrenches set.
- Open-jawed spanner 10.
- Scissors.
- Flexo-meter.
- Ø10 Wrench.
- Phillips screwdriver / screwdriver.
- Ø35 Circular saw.
- Ø7 Drill.
- Sabre saw.



Associated documentation

- Quick guide: 1002455105
- User manual: 1002192411
- List of spare parts: 1003714494
- Troubleshooting: 1002192414

Dirna Bergstrom declares that the **INTEGRAL POWER** unit complies with the requirements of the following EC Directives and that the harmonised standards and technical specifications listed below have been applied:

- EC Directive 2014/53/EU
- EC Directive 2011/65/EU
- EC Directive 2014/30/EU



Important: The **Integral Power II** has 4 plates welded to the sides of the base in order to ensure safe lifting using mechanical lifting equipment.

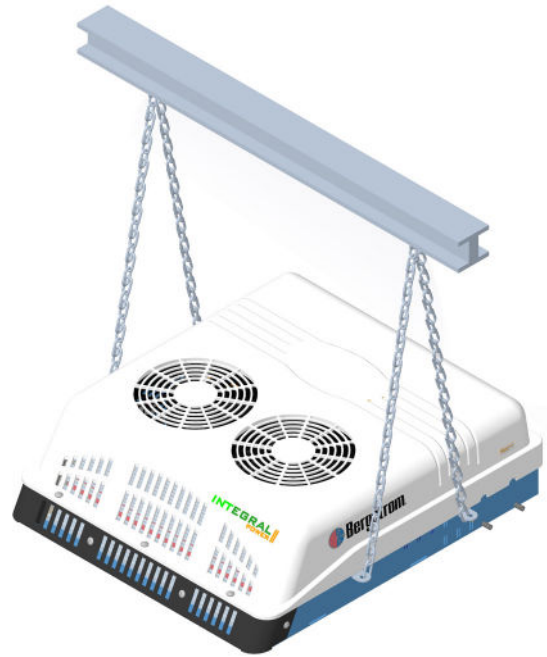
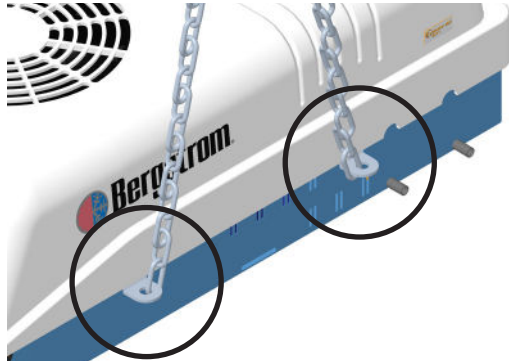

1 Position the **Integral Power II** unit on the roof, taking into account that the final position must correspond to the front supplied, ensuring it is on a flat surface.

2 Once the position is defined, remove the case and mark (6) boreholes (Y), then align the (4) template boreholes with the (4) rear boreholes in the roof (figure 3).

Note the arrow indicating the operation direction.

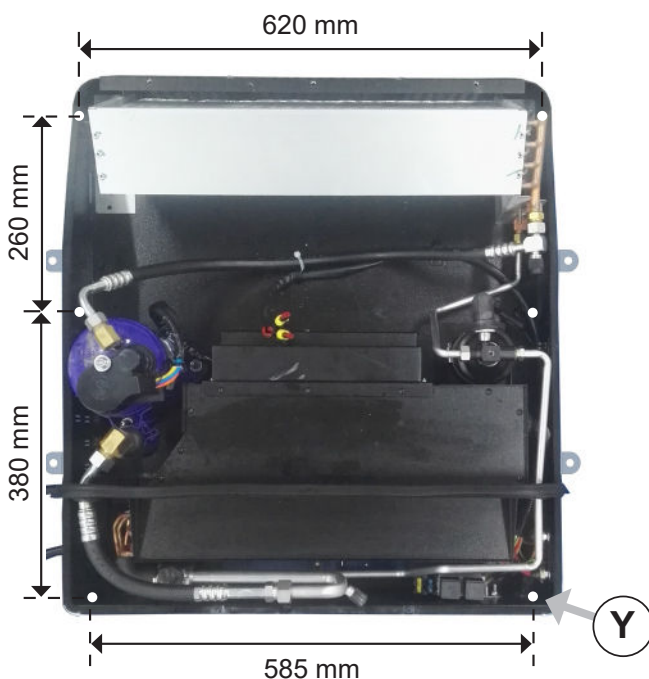
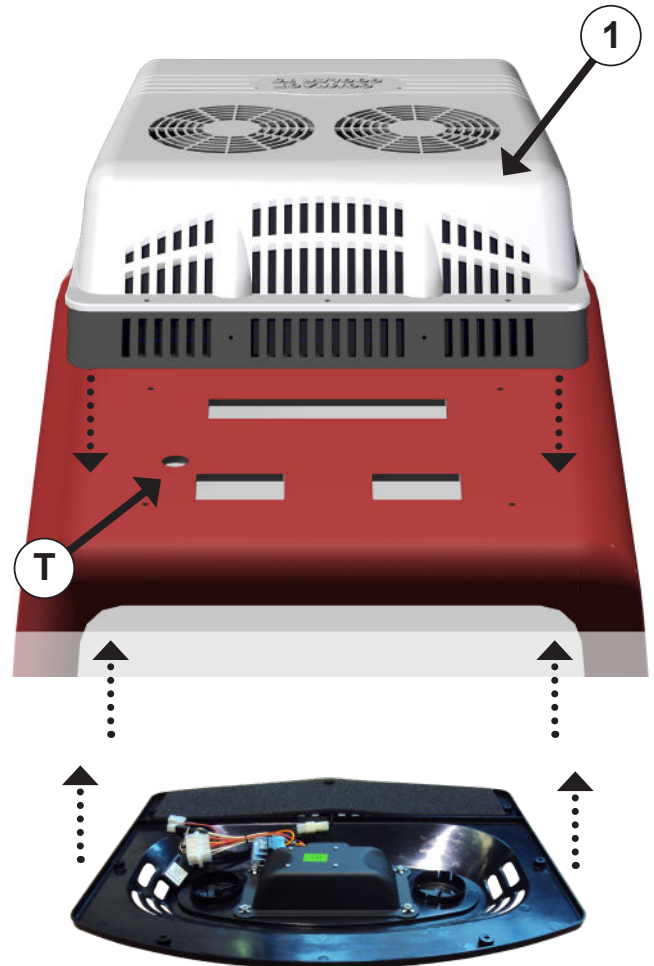

3 Mark and make the cuts and boreholes (protect the sharp edges with anti-oxidant).

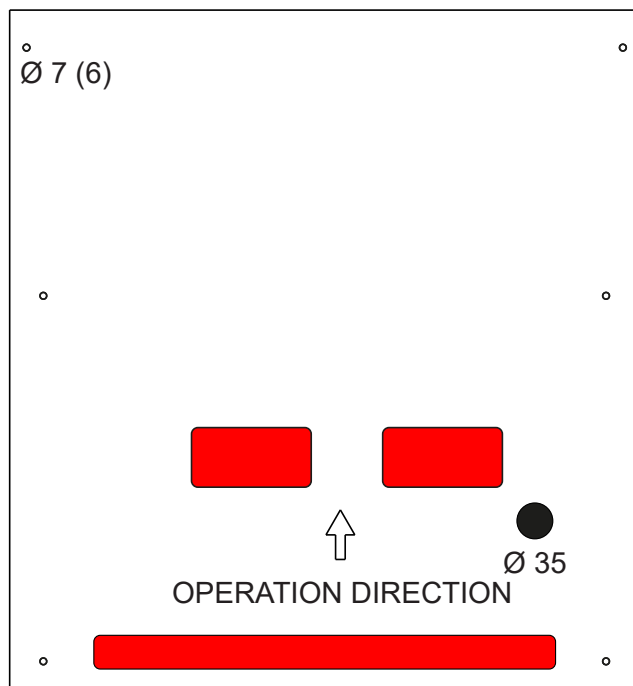

4 Position the seal joint, side seals and front seal inside the compact as shown.

a	Seal joint
b	Side seals
c	Front seal

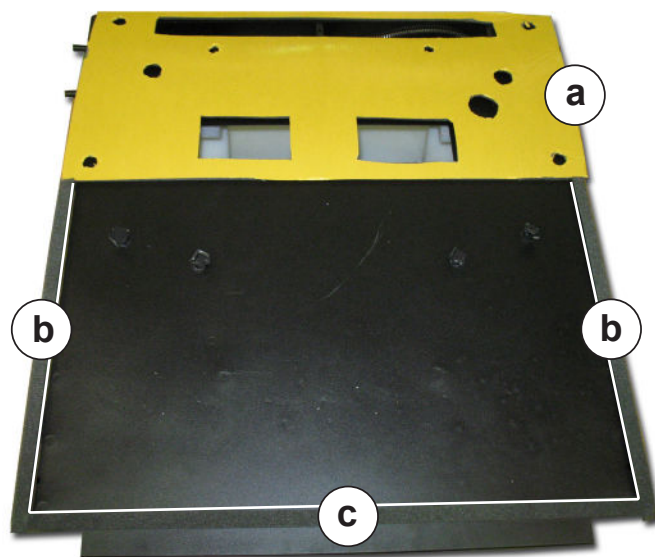

5 Pass the cabling through the borehole (T) made for this purpose in the roof (figure 1). Position Integral Power (A) with (6) 13 mm pieces of bushing, rubber washers and (6) M6/100x40 screws (B) and nuts M6/100.

Important: Ensure sealtightness between the unit and the ceiling in order to prevent any water coming in.

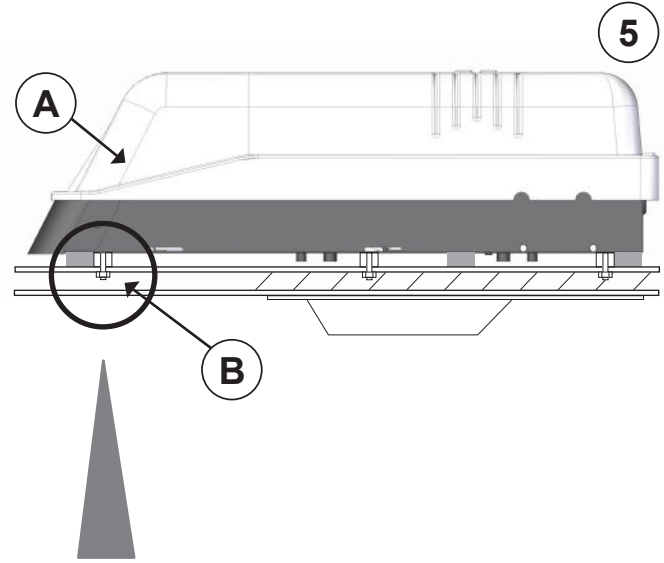

6a Insert rubber washers to prevent water passage.

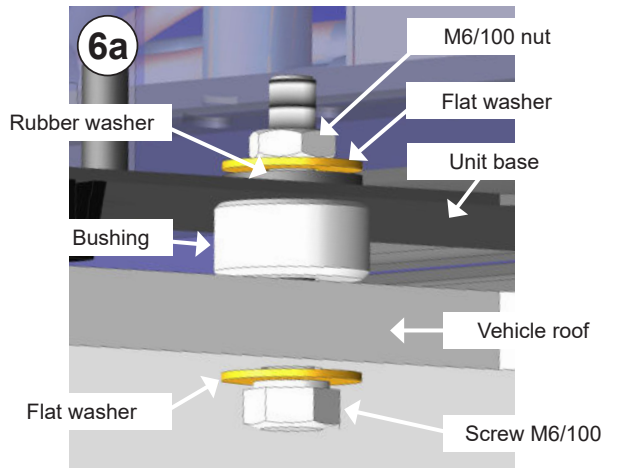

6b Position Ø9 x Ø13 PVC pipes, as supplied, in the unit in accordance with required length.

 **Caution:** Position drainage valves at the end of the PVC pipes for the water to run off.

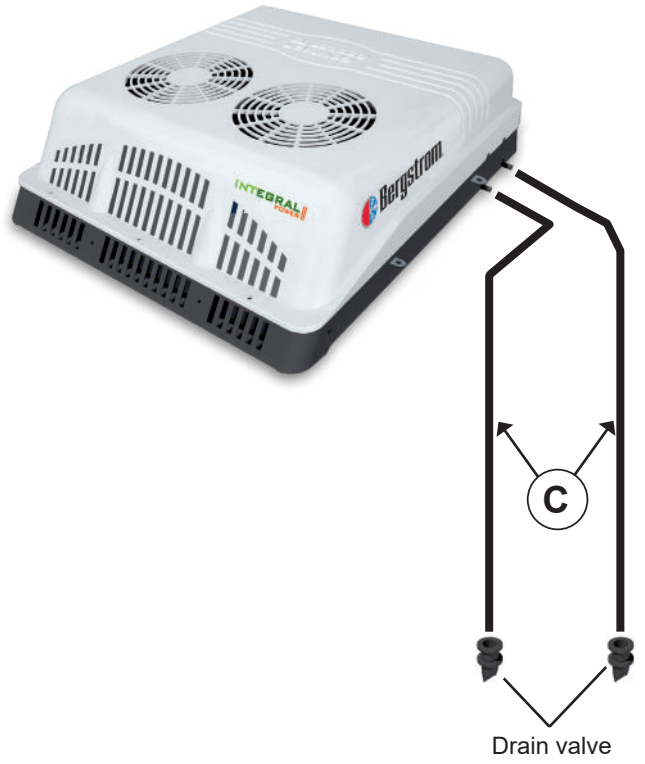

Connection to alternator cable for unit operation with the engine running

 **Caution:** The cable will be installed in all vehicles for the unit to work with the engine started up.

7 Position excitation cable on the inside or outside of the vehicle as appropriate, and secure the front with the supplied self-tapping screws. Connect switches as shown.

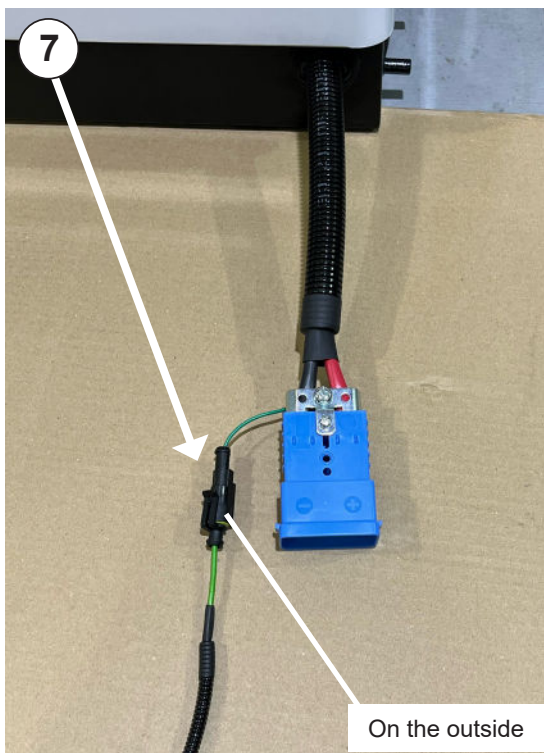
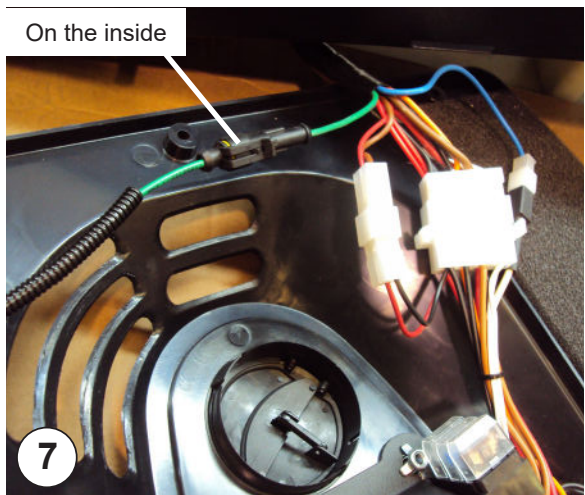

8 Connect the other end of the supplied cable in position (+) only with the engine started up or through the (+) ignition key.

9 Connect the power cable in the rear of the unit.
Run the power cable to the vehicle's battery.
Important: When connecting the cables, leave suitable distance in order to prevent breakage when the vehicle moves.

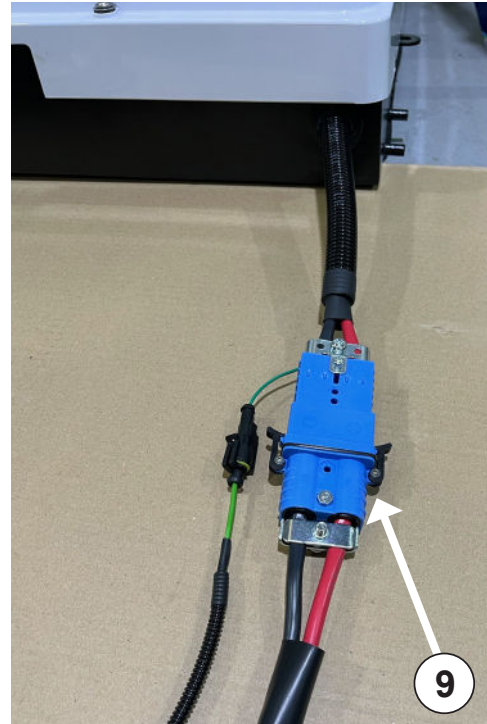

10 For vehicles with a tilting cab, two warning stickers have been added to remind users to disconnect the unit's power cable before tilting the cab.
Place the stickers next to the cab tilting mechanism and the power cable connections.



 **Note:** There is an optional 3-metre cable extension for vehicles that require a longer power cable or have a tilting cab, reference: 1003713621.



 **Important:** Check the user manual: 1002192411 before starting up.

Electric wiring

Az	Blue
N	Black
R	Red
V	Green
B	White
A	Yellow
Na	Orange
M	Brown

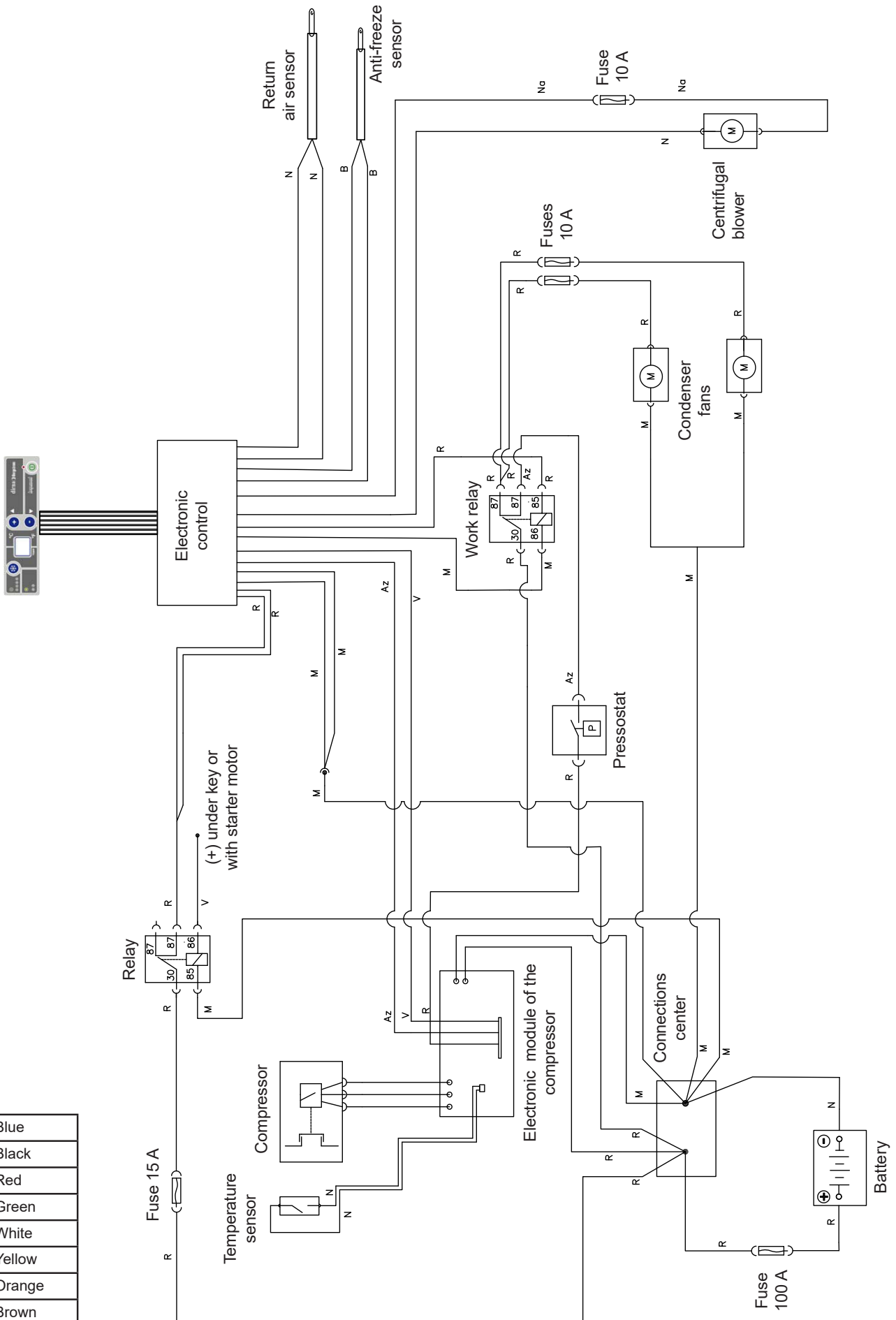



Veillez lire attentivement ce document avant d'installer le produit. Conservez ce document pour toute référence ultérieure. La documentation d'origine a été rédigée en espagnol, les autres langues sont donc des traductions.

Vous avez à votre disposition tous les manuels des produits dans leurs versions numériques (PDF) sur <https://www.bergstromspain.com/>

Toute opération de vente ou de garantie est soumise à nos conditions générales de vente dans leur version la plus à jour, publiée sur notre site Web <https://www.bergstromspain.com/>

Explication des symboles



- **Mise en garde** : Avis de sécurité informant d'une situation qui, si elle n'est pas évitée, pourrait conduire à des blessures graves ou la mort.



- **Danger** : Risque de coupure. Signale une situation qui pourrait conduire à une coupure.



- **Danger** : Risque d'électrocution. Signale une situation qui pourrait conduire à une électrocution.



- **Avertissement** : Avis de sécurité informant d'une situation qui, si elle n'est pas évitée, pourrait entraîner des dommages matériels (équipement ou autre).



- **Information** : Information complémentaire sur l'installation ou la manipulation du produit.



- **Fragile** : Indique une situation dans laquelle il faut procéder avec précaution afin de ne pas endommager l'équipement ou d'autre matériel.



Explication des responsabilités

- **Dirna Bergstrom** décline toute responsabilité en termes de dommages causés dans les cas suivants :

- Dommages au produit dus à des influences mécaniques et à des surtensions.
- Modifications apportées à l'équipement sans le consentement exprès du fabricant.
- Utilisation de l'équipement à des fins non décrites dans ce document.
- Manipulation ou installation inappropriée de l'équipement.

- La manipulation des circuits de gaz réfrigérant sans autorisation expresse du fabricant est interdite.



Mises en garde au cours du montage

- L'installation, la réparation et l'entretien de cet équipement de climatisation ne peuvent être réalisés que par un personnel technique suffisamment formé sur la climatisation des véhicules, les dangers éventuels et les normes applicables.
- Lire attentivement les consignes de montage avant de commencer l'installation de l'équipement. Pendant l'installation, suivre au pied de la lettre les consignes indiquées.
- Lors de l'installation de l'appareil d'air conditionné sur le toit, il faudra protéger la partie supérieure de la cabine avec un linge ou une couverture de protection afin d'éviter les éventuelles égratignures. Durant l'installation du **INTEGRAL POWER**, tenir compte du fait que normalement les cabines pourvues d'écouille possède une structure suffisamment solide pour supporter le poids de l'appareil. Cependant, si ce n'est pas le cas et qu'il est nécessaire de découper le toit ou même si disposant d'écouille, la structure n'est pas suffisamment rigide (si elle était en fibre, plastique, etc.) il appartiendra à l'installateur de décider s'il faut renforcer le toit pour éviter toute déformation, rupture ou voie d'eau, etc., et prendre les mesures nécessaires à cet effet.
- Débrancher la clé de contact avant de commencer l'installation de l'équipement.
- Débrancher la batterie du véhicule avant de commencer l'installation de l'équipement.
- Installez **INTEGRAL POWER** en toute sécurité afin d'éviter les chutes.
- Utiliser les outils appropriés à chaque opération.
- Pendant l'installation, s'assurer du raccordement des composants électriques en vérifiant leur bon ajustement.
- Si lors de l'installation de l'équipement, les câbles traversent des murs à arêtes vives, utilisez des conduits ou des dispositifs de guidage, afin d'éviter l'endommagement des câbles.
- Si pendant son installation, l'équipement s'incline ou la cabine se rabat avec l'équipement installé dessus, attendez au moins 60 minutes, à compter du moment où l'équipement est à l'horizontale, avant de le mettre en marche.

- Équipement préchargé en gaz réfrigérant r-134a.



- **Avertissement important** : Toute modification des systèmes ROPS / FOPS, comme le soudage ou le perçage de trous dans des pièces structurales, affectera la capacité de ROPS / FOPS à fournir la protection requise. L'installation de ce produit peut affecter les systèmes ROPS / FOPS.

Contactez votre distributeur agréé pour vérifier la compatibilité avant d'effectuer des modifications ou des réparations; dans le cas contraire, vous pouvez annuler la certification ROPS / FOPS. Le fabricant du système de climatisation de toit n'assume aucune responsabilité.



Outils requis pour le montage

- Jeu de clés Torx.
- Jeu de clés Allen.
- Clé fixe 10.
- Ciseaux.
- Mètre.
- Jeu de clés à cliquet - mèche Ø 10.
- Tournevis étoile / tournevis.
- Scie circulaire Ø 35.
- Perceuse - mèche Ø 7.
- Scie sauteuse.



Documentation connexe

- Guide rapide : 1002455105
- Mode d'emploi : 1002192411
- Liste de pièces de rechange : 1003714494
- Diagnostic de pannes : 1002192414

Dirna Bergstrom déclare que l'équipement **INTEGRAL POWER** satisfait aux exigences des Directives CE suivantes, et que les normes et spécifications techniques harmonisées énumérées ci-dessous ont été appliquées :

- Directive CE 2014/53/UE
- Directive CE 2011/65/UE
- Directive CE 2014/30/UE



Important : L'équipement **Integral Power II** est muni de 4 goussets soudés sur les côtés de la base pour assurer un levage en sécurité au moyen d'un équipement mécanique de levage.

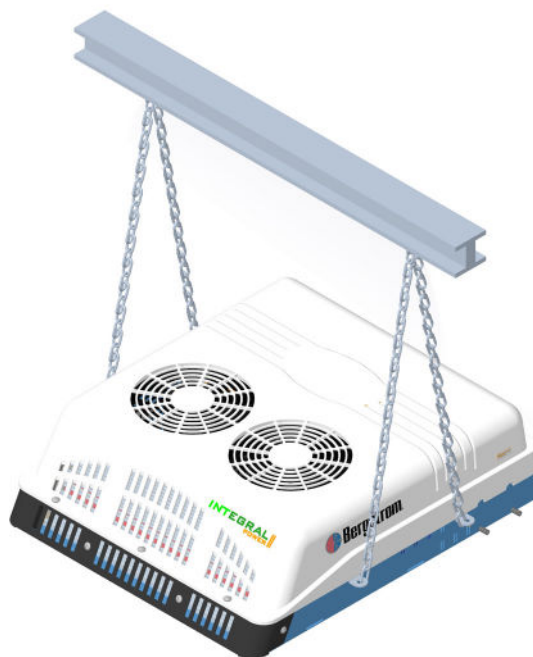
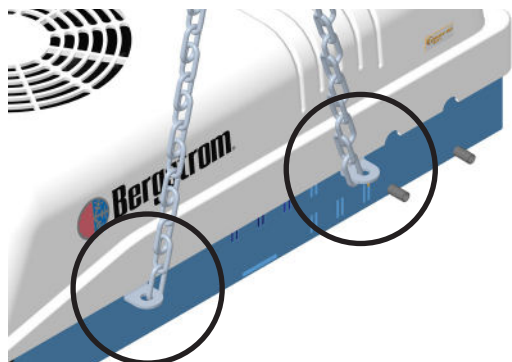

1

Situer l'équipement **Integral Power II** sur le plafond. La position finale doit correspondre à la partie frontale fournie. Il doit être placé sur une surface plate.

2

Une fois que la position est définie, retirer la carcasse et marquer (6) trous (Y) et faire ensuite coïncider les (4) trous du patron avec les (4) trous arrière du plafond (figure 3).

Tenir compte de la flèche qui indique le sens de la course.

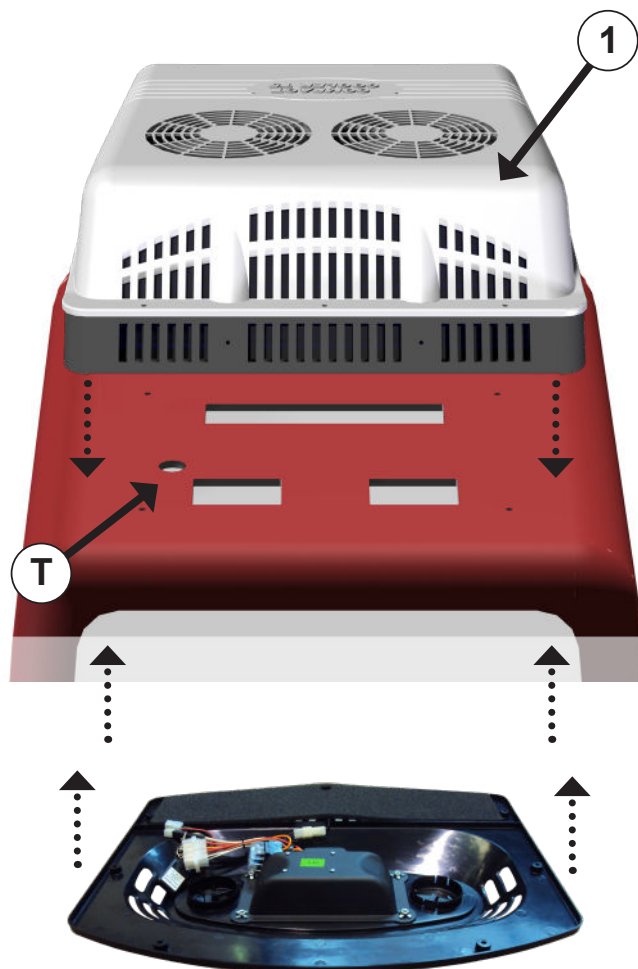
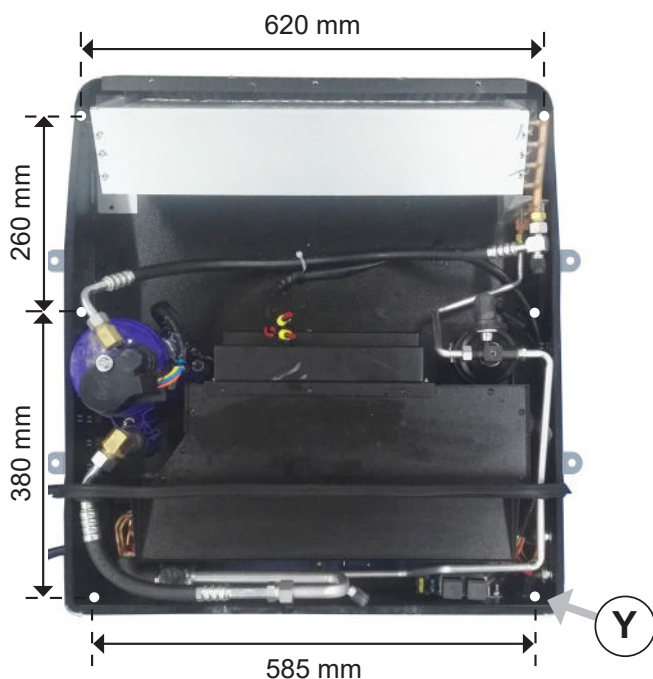

3 Marquer les coupes et les trous et les réaliser (protéger les bords coupés avec de l'antioxydant).

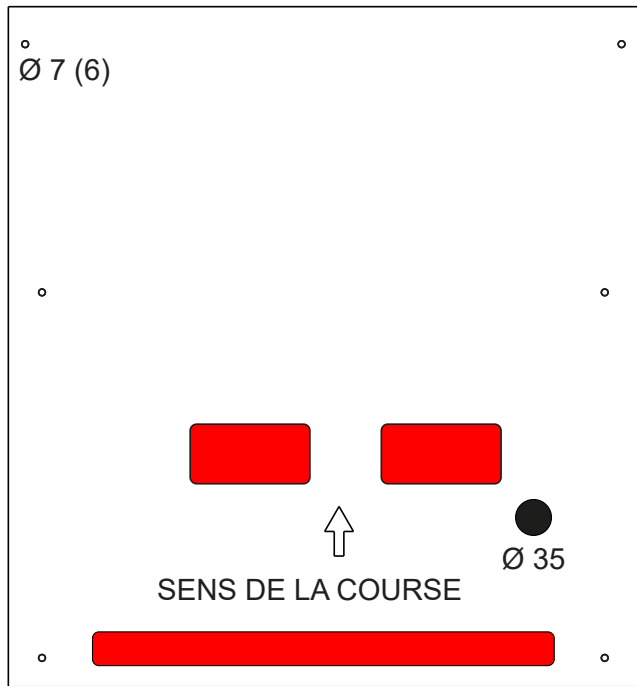

4 Placer le joint d'étanchéité, les joints latéraux et le joint frontal sur la partie intérieure du Integral Power comme cela est indiqué.

a	Joint étanchéité
b	Joints latéraux
c	Joint frontal

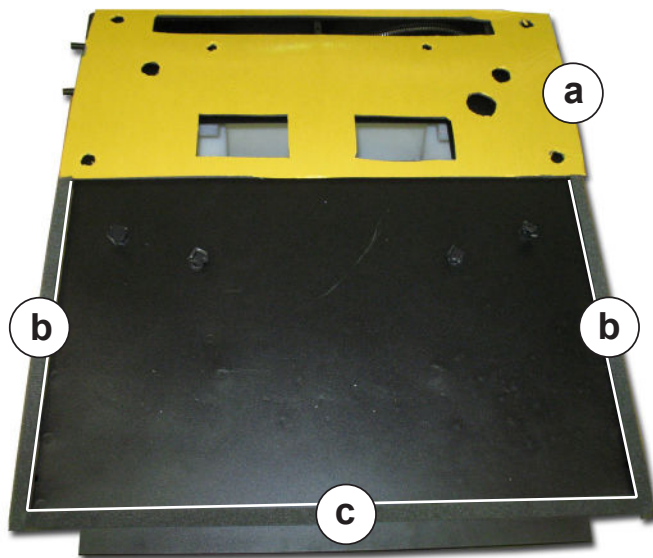

5

Passer le câblage à travers le trou (T) réalisé sur le plafond à cet effet (figure 1). Placer ensuite l'Integral Power (A) avec (6) douilles de 13 mm, des rondelles en caoutchouc et (6) vis M6/100 (B) et écrous M6/100.



Important : assurer l'étanchéité de l'ensemble sur le plafond pour éviter de possibles entrées d'eau.



5

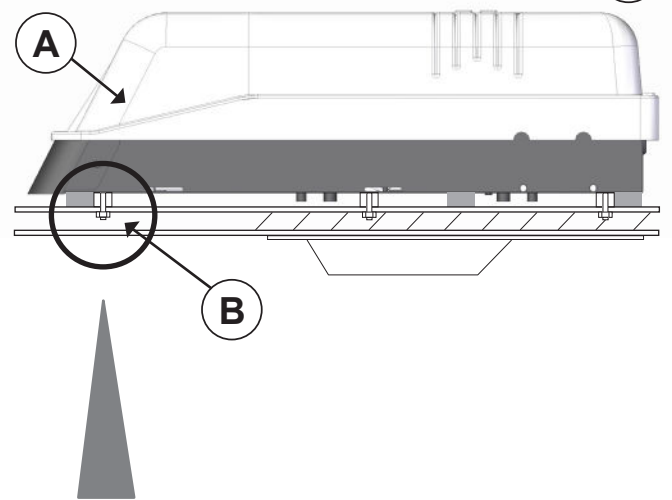

6a

Placer les rondelles en caoutchouc pour éviter le passage de l'eau.

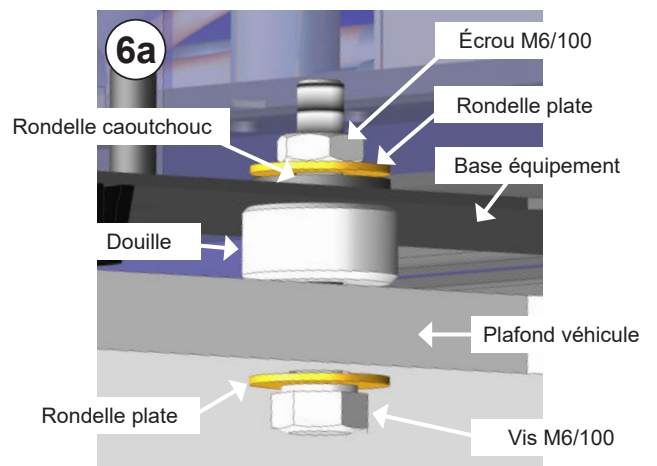

6b

Placer les tuyaux en PVC Ø 9 x Ø 13 fournis dans l'équipement selon le besoin de longueur.



Attention: placer les vannes de drainage à la fin des tuyaux en PVC pour faciliter le drainage de l'eau.

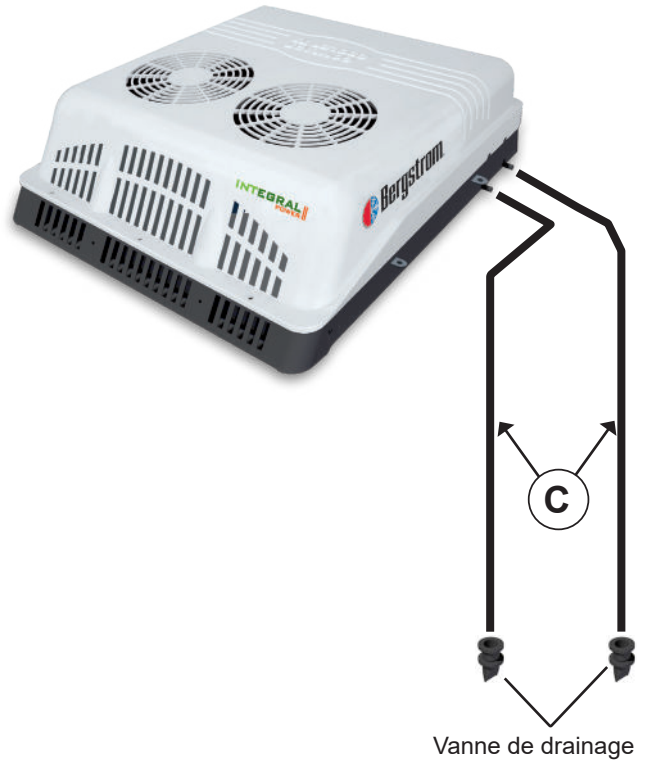

Câblage de connexion à alternateur pour fonctionnement équipement avec moteur en marche



Attention: le câblage sera installé dans tous les véhicules pour que l'équipement fonctionne avec le moteur démarré.

7

Placer le câblage d'excitation à l'intérieur ou à l'extérieur du véhicule et monter avec les vis taraudeuses fournies. Connecter les interrupteurs comme cela est indiqué.

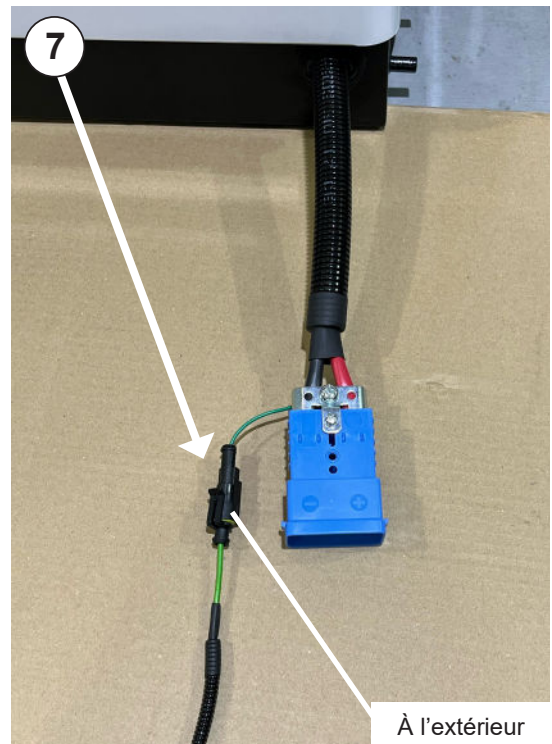
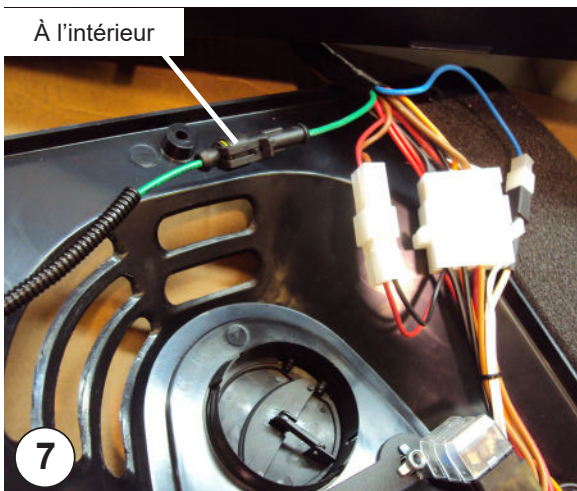

8

Connecter l'autre extrémité du câblage fourni sur la position (+) uniquement avec le moteur démarré ou à travers (+) clé de contact.

9

Connectez le câble d'alimentation à l'arrière de l'unité.

Faites passer le câble d'alimentation jusqu'à la batterie du véhicule.

Important: Au moment de connecter les câblages, prévoir une distance suffisante pour éviter leur rupture à cause des mouvements du véhicule.

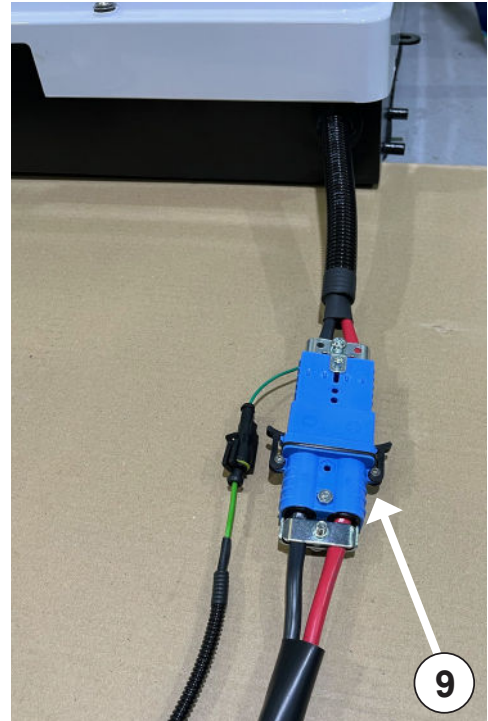

10

Pour les véhicules dont la cabine est rabattue, deux autocollants d'avertissement ont été ajoutés dans le but de rappeler le besoin de déconnecter le câblage d'alimentation de l'unité avant de rabattre la cabine.

Placez les autocollants à côté du mécanisme de rabattement de la cabine et la connexion des câblages d'alimentation.



Attention : pour les véhicules exigeant une plus grande longueur de câble d'alimentation ou dont la cabine est rabattue, une rallonge de câble de 3 mètres est disponible en option : 1003713621.



Important : Pour la mise en marche, consultez le manuel de l'utilisateur : 1002192411.

Câblage électrique

Az	Bleu
N	Noir
R	Rouge
V	Vert
B	Blanc
A	Jaune
Na	Orange
M	Marron

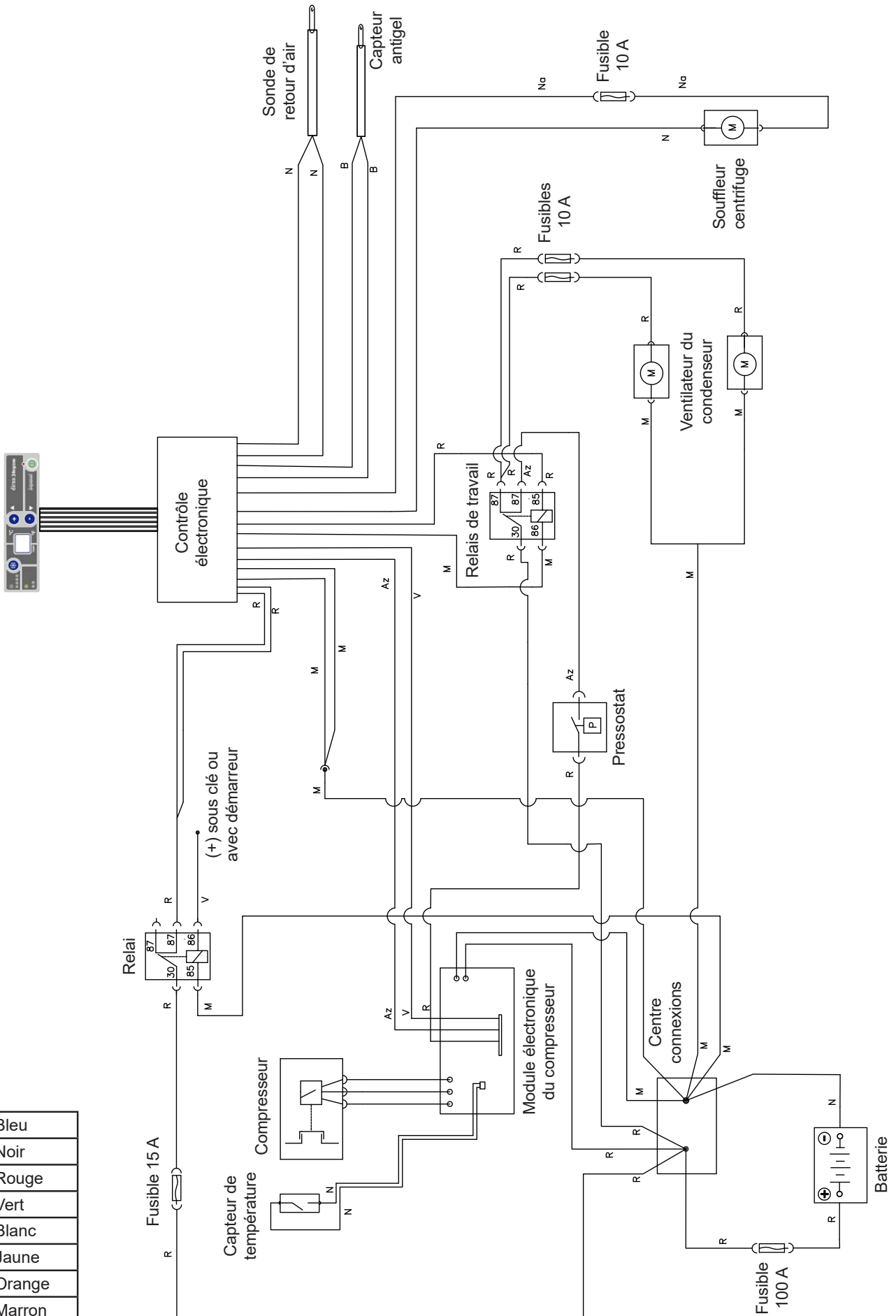



Bitte lesen Sie dieses Dokument vor der Installation des Produkts sorgfältig durch und bewahren Sie es zum späteren Nachschlagen auf. Die Originaldokumentation wurde in spanischer Sprache verfasst; bei allen anderen Sprachen handelt es sich um Übersetzungen.

Alle Produktanleitungen sind in digitaler Form unter <https://www.bergstromspain.com/> erhältlich.

Für alle Verkäufe und Garantievorgänge gelten unsere allgemeinen Geschäftsbedingungen in ihrer jeweils aktuellen Fassung, die auf unserer Website <https://www.bergstromspain.com/> veröffentlicht sind.

Verwendete Symbole



- **Achtung:** Sicherheitshinweis, der auf eine Situation hinweist, die, wenn sie nicht vermieden wird, zum Tod oder zu schweren Verletzungen führen kann.



- **Gefahr:** Schnittgefahr. Weist auf eine Situation hin, die zu Schnittverletzungen führen kann.



- **Gefahr:** Stromschlaggefahr. Weist auf eine Situation hin, die zu einem Stromschlag führen kann.



- **Hinweis:** Sicherheitshinweis, der auf eine Situation hinweist, die, wenn sie nicht vermieden wird, zum Schäden am Gerät oder anderen Gegenständen führen kann.



- **Information:** Zusatzinformationen zu Installation oder Handhabung des Produkts.



- **Zerbrechlich:** Weist auf eine Situation hin, in der Vorsicht geboten ist, um Schäden am Gerät und anderen Gegenständen zu vermeiden.



Haftung

- **Dirna Bergstrom** lehnt in den folgenden Fällen jede Haftung für Schäden ab:

- Beschädigung des Produkts durch mechanische Einflüsse und Überspannung.
- Änderungen am Gerät, die ohne ausdrückliche Genehmigung des Herstellers vorgenommen wurden.

- Verwendung des Geräts für Zwecke, die nicht in diesem Dokument beschrieben sind.
- Unsachgemäße Handhabung oder Installation des Geräts.

- Ohne ausdrückliche Genehmigung des Herstellers dürfen keine Eingriffe in die Kältemittelkreisläufe vorgenommen werden.



Warnhinweise hinsichtlich der Montage

- Einbau, Reparatur und Wartung dieser Klimaanlage dürfen nur von Fachpersonal durchgeführt werden, das in Bezug auf Fahrzeugklimatisierung, mögliche Gefahren und geltende Normen ausreichend geschult ist.
- Bitte lesen Sie die Installationsanleitung sorgfältig durch, bevor Sie mit der Installation des Geräts beginnen. Befolgen Sie bei der Installation genau die hier gegebenen Anweisungen.
- Wird die Klimaanlage im Kabinendach installiert, muss der obere Teil der Kabine mit einem Tuch oder einer Decke gegen eventuelle Kratzer geschützt werden. Bei der Installation der **INTEGRAL POWER** auf dem Kabinendach muss darauf geachtet werden, dass mit Luken ausgestattete Kabinen über eine ausreichend stabile Struktur verfügen, um das Gewicht des Geräts stand zu halten. Sollte das Fahrzeug über keine Luke verfügen und sollte es notwendig sein, das Kabinendach aufzuschneiden, bzw. sollte die vorhandene Struktur nicht ausreichend stabil sein (z.B. wenn sie aus Faser, Kunststoff usw. hergestellt ist), obliegt es dem Installateur zu entscheiden, ob das Kabinendach zur Vermeidung von Verformungen, Brüchen, undichten Stellen usw. verstärkt werden muss, und die hierfür notwendigen Mittel bereit zu stellen.
- Vor der Installation des Geräts den Zündschlüssel ausschalten.
- Vor der Installation des Geräts die Fahrzeugbatterie abklemmen.
- Die **INTEGRAL POWER** sicher anbringen, damit sie nicht herunterfallen kann.
- Für jeden Arbeitsschritt geeignete Werkzeuge benutzen.
- Bei der Installation auf den Anschluss der elektrischen Komponenten achten und prüfen, ob diese richtig sitzen.
- Wenn die Kabel bei der Installation des Geräts entlang scharfkantiger Wände verlaufen,

Leerrohre oder Führungen benutzen, um eine Beschädigung der Kabel zu vermeiden.

- Wird das Gerät während der Installation geneigt oder das Fahrerhaus mit montiertem Gerät gekippt, müssen ab dem Zeitpunkt, zu dem das Gerät wieder waagrecht liegt, mindestens 60 Minuten vergehen, bevor es in Betrieb genommen wird.
- Das Gerät ist mit Kältemittel R-134a vorgefüllt.



- **Wichtiger Hinweis:** Jegliche Modifikation bezüglich ROPS/FOPS, wie zum Beispiel das Schweißen oder das Bohren von Löchern in tragenden Teilen, beeinflusst die ROPS/FOPS-Kapazität, den gewünschten Schutz bereitzustellen. Die Installation dieses Produktes kann sich auf die ROPS/FOPS-Systeme auswirken.

Wenden Sie sich an Ihren autorisierten Händler, um die Kompatibilität zu überprüfen, bevor Sie irgendwelche Modifikationen oder Reparaturen durchführen. Andernfalls kann die ROPS/FOPS-Zertifizierung ungültig werden. Der Hersteller der Dach-Klimaanlage übernimmt keinerlei Haftung.



Für die Montage erforderliche Werkzeuge

- Torx-Schraubenschlüssel.
- Inbusschraubenschlüssel.
- 10er Schraubenschlüssel.
- Schere.
- Metermaß.
- Drehmomentratsche - Ø 10.
- Kreuzschraubendreher / Schraubendreher.
- Kreissäge Ø 35.
- Bohrer - Ø 7.
- Stichsäge.



Zugehörige Dokumente

- Kurzanleitung: 1002455105
- Bedienungsanleitung: 1002192411
- Ersatzteilliste: 1003714494
- Fehlerbehebung: 1002192414

Dirna Bergstrom erklärt, dass das Gerät **INTEGRAL POWER** den Anforderungen der folgenden EG-Richtlinien entspricht und dass die unten aufgeführten harmonisierten Normen und technischen Spezifikationen angewendet wurden:

- Richtlinie 2014/53/EU
- Richtlinie 2011/65/EU
- Richtlinie 2014/30/EU



Wichtiger Hinweis: Das Gerät **Integral Power II** hat 4 seitlich am Sockel angeschweißte Lochlaschen, um ein sicheres Anheben mit einer mechanischen Hebevorrichtung zu ermöglichen.

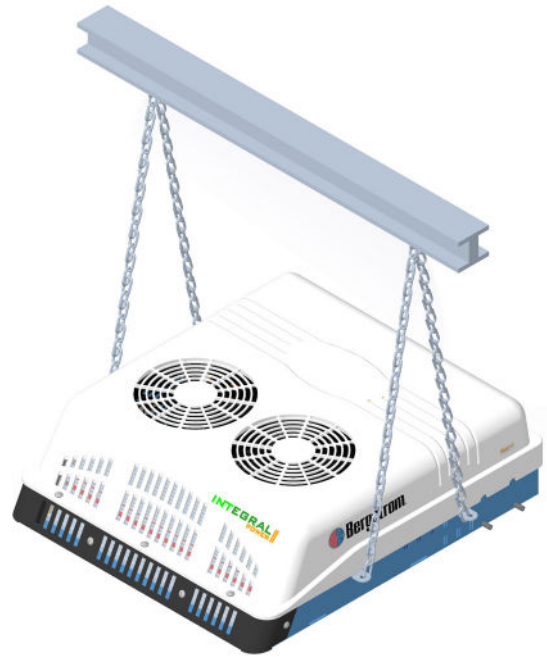
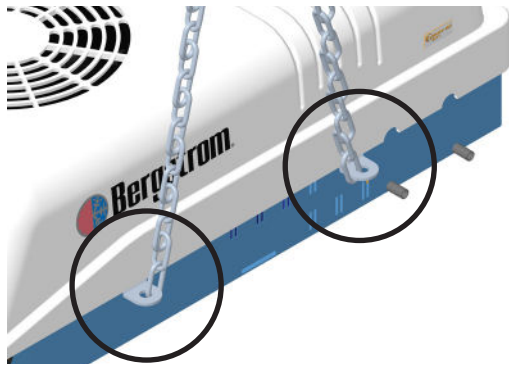

1 **Integral Power II** auf einer ebenen Fläche auf dem Dach positionieren. Dabei berücksichtigen, dass die endgültige Position mit der mitgelieferten Front übereinstimmen muss.

2 Nach Festlegung der Position, das Gehäuse abnehmen und (6) Löcher (Y) markieren. Danach die (4) Bohrlöcher der Vorlage mit (4) hinteren Löchern des Dachs (Abb. 3) in Übereinstimmung bringen.

Auf den Pfeil achten, der die Fahrtrichtung anzeigt.

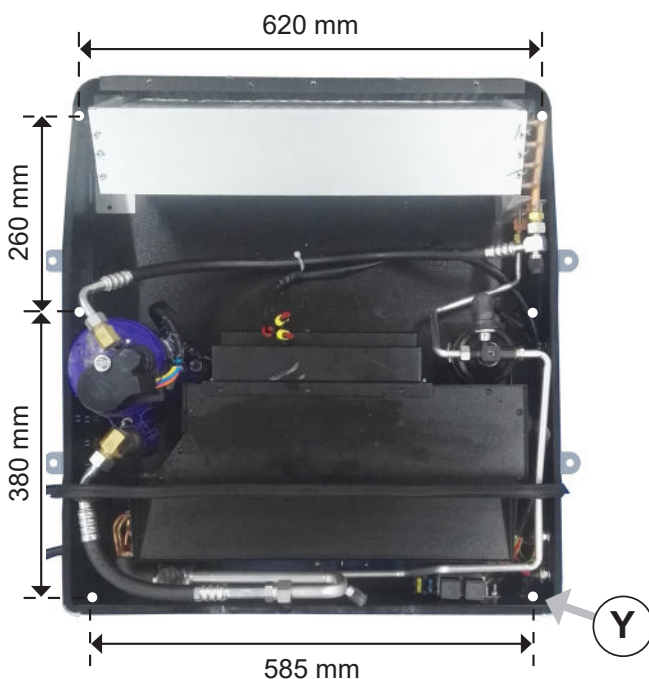
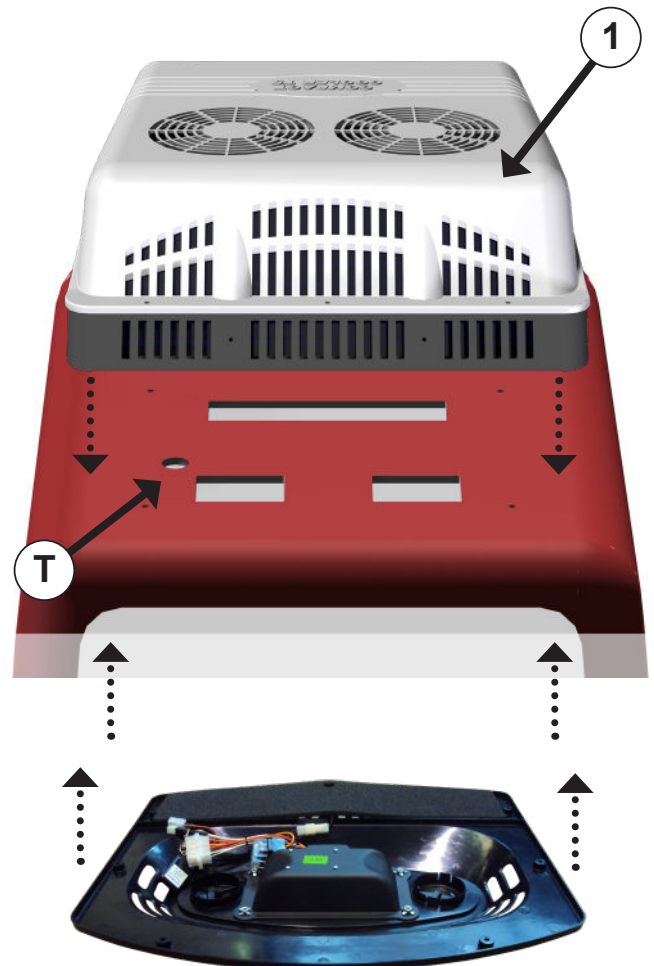

3 Die Schnitte und Bohrlöcher markieren und durchführen (die Schnittkanten mit Rostschutzmittel schützen).

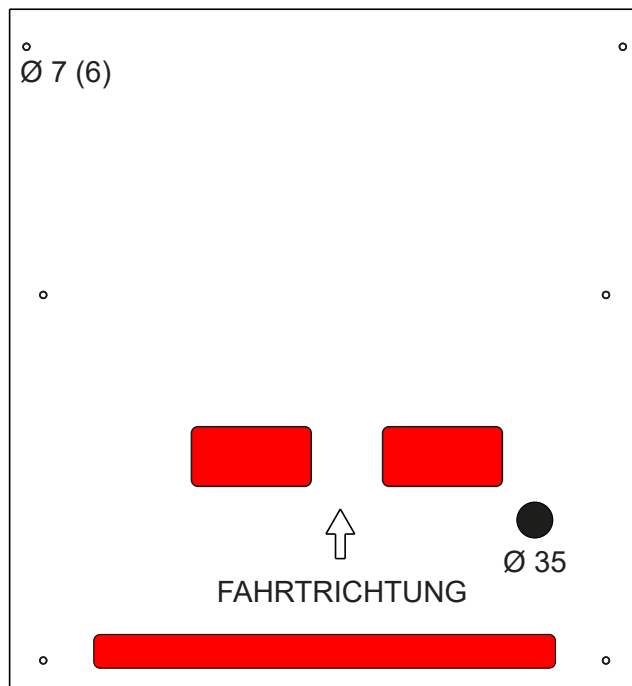

4 Verschlussdichtung, Seitendichtungen und Frontdichtung auf der Innenseite der Kompaktanlage wie gezeigt anbringen.

a	Verschlussdichtung
b	Seitendichtungen
c	Frontdichtung

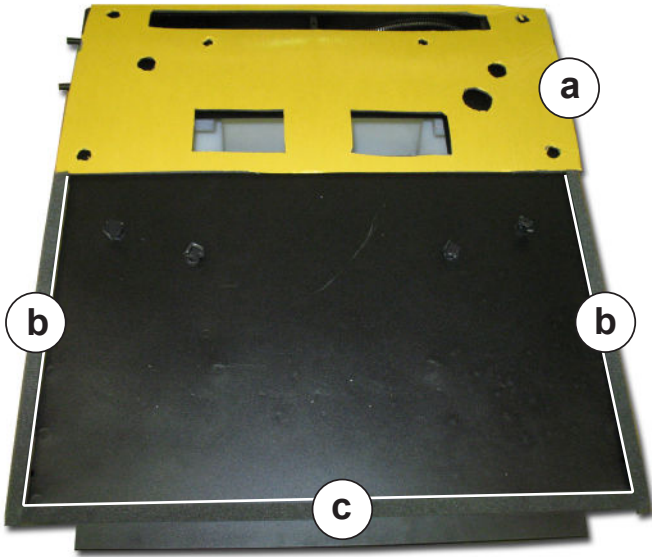

5 Kabel durch das hierfür angefertigte Bohrloch (T) führen (Abb. 1). **Integral Power G2 (A)** mit (6) 13 mm Hülsen, Gummischeiben und (6) Schrauben M6/100x40 (B) und Muttern M6/100 anbringen.

Wichtiger Hinweis: Dichtigkeit der Baugruppe zum Dach hin sicherstellen, um möglichen Wassereintritt zu verhindern.

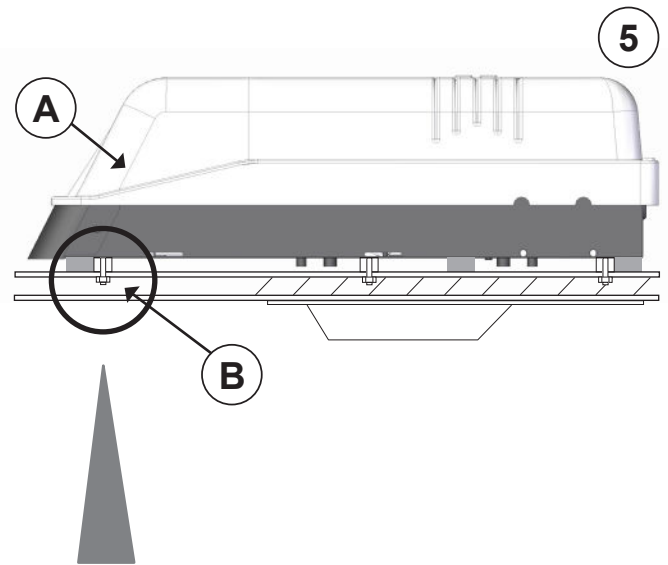

6a Gummiunterlegscheiben zur Vermeidung von Wassereintritt anbringen.

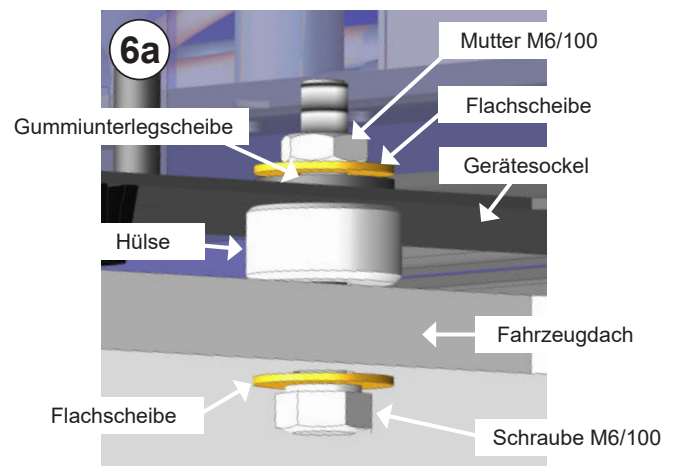

6b

Mitgelieferte PVC-Schläuche $\varnothing 9 \times \varnothing 13$ je nach Längenbedarf verlegen.



Achtung: Drainageventile am Ende der PVC-Schläuche anbringen, damit das Wasser ablaufen kann.

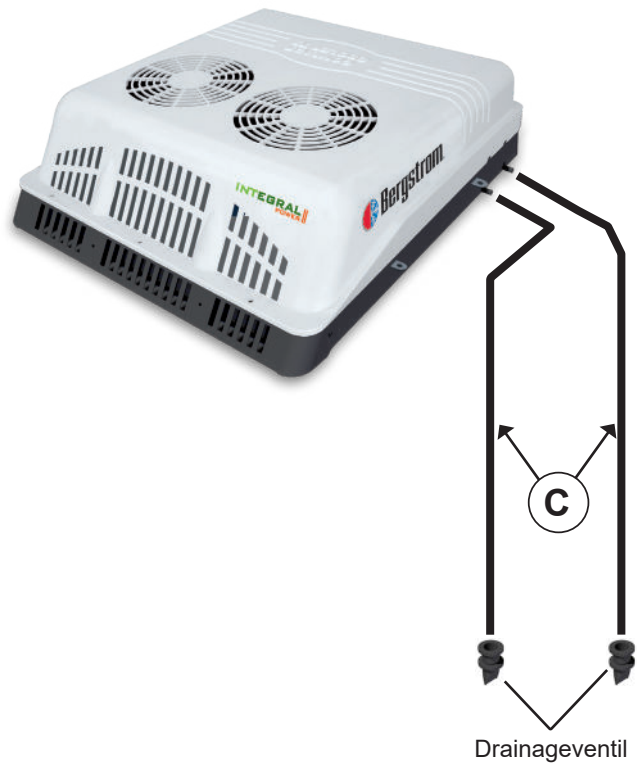

Alternatoranschlussverkabelung für den Betrieb des Geräts bei laufendem Motor



Achtung: Die Kabel in allen Fahrzeugen installieren, damit das Gerät bei laufendem Motor funktioniert.

7

Erregerkabel von innen oder außen her verlegen und Front mit den mitgelieferten Blechschrauben befestigen. Schalter wie gezeigt anschließen.

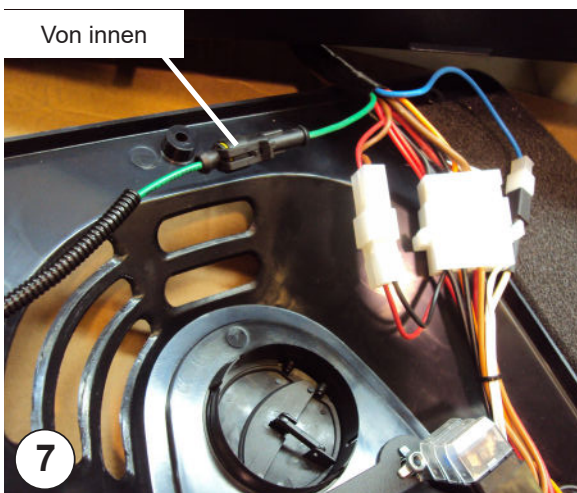
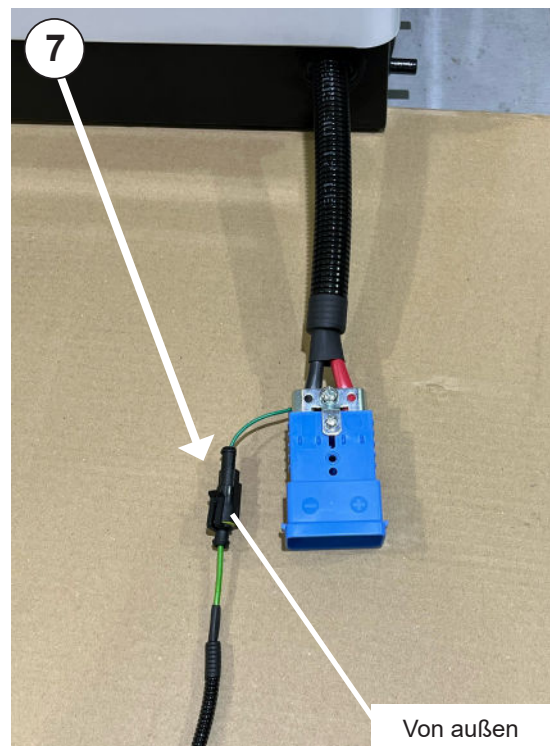

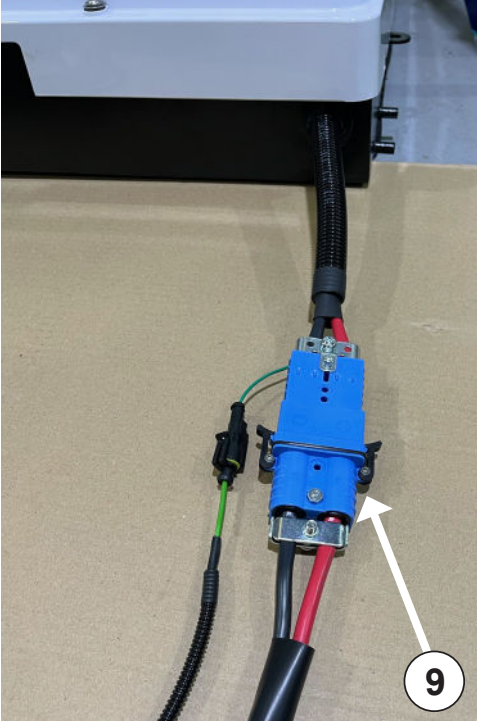

8 Das andere Ende des mitgelieferten Kabels in Position (+) nur bei laufendem Motor oder über (+) Kontaktschlüssel anschließen.

9 Stromversorgungskabel hinten am Gerät anschließen.
 Stromversorgungskabel zur Fahrzeugbatterie führen.
Wichtiger Hinweis: Beim Anschluss der Kabel ausreichenden Abstand lassen, um deren Bruch durch die Bewegungen des Fahrzeugs zu vermeiden.

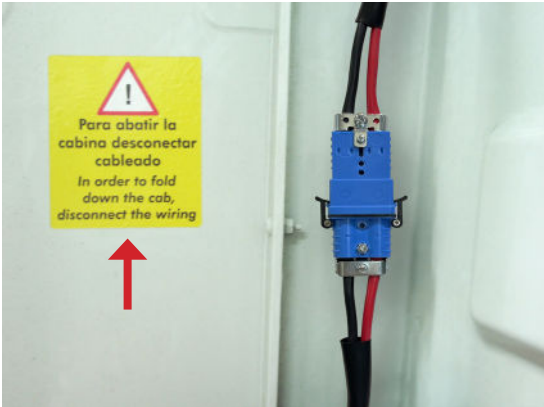

10 Für Fahrzeuge mit kippbarem Fahrerhaus werden 2 Warnaufkleber mitgeliefert, die darauf hinweisen, dass vor dem Kippen des Fahrerhauses die Stromversorgungskabel des Geräts getrennt werden müssen.
 Diese Aufkleber in der Nähe des Kippmechanismus und des Anschlusses für die Stromversorgungskabel anbringen.



 **Achtung:** Für Fahrzeuge, die eine längere Stromversorgungsleitung benötigen oder deren Fahrerhaus kippbar ist, gibt es ein als Option erhältliches 3-Meter-Verlängerungskabel mit der Referenz 1003713621.



 **Wichtiger Hinweis:** Für die Inbetriebnahme, lesen Sie bitte im Benutzerhandbuch (1002192411) nach.

Elektrische Verkabelung

Az	Blau
N	Schwarz
R	Rot
V	Grün
B	Weiss
A	Gelb
Na	Orange
M	Braun

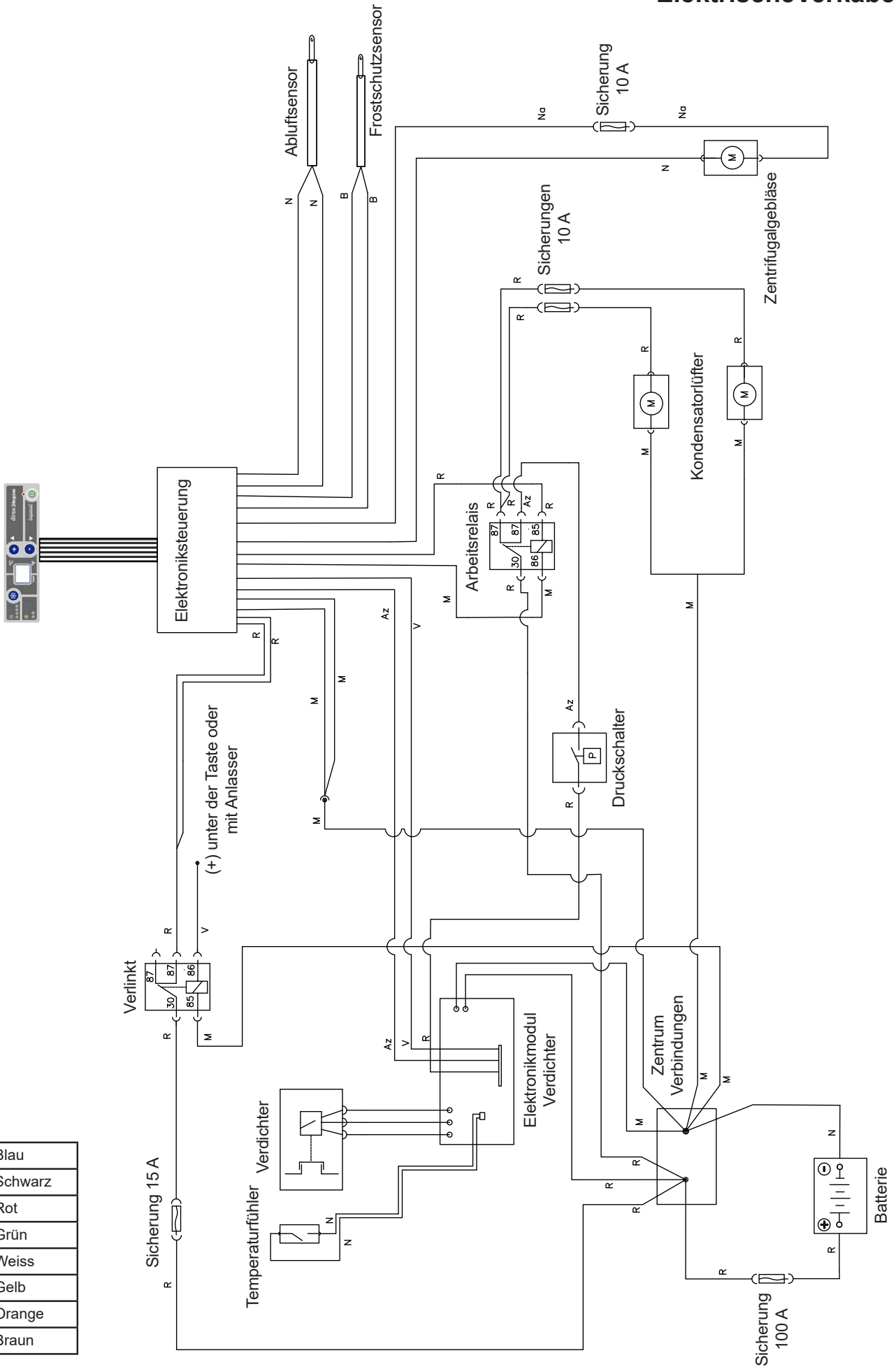



Leggere attentamente questo documento prima di installare il prodotto. Conservare questo documento con cura per poterlo consultare in futuro. La documentazione originale è stata stilata in spagnolo, perciò le altre lingue sono traduzioni.

Tutti i manuali del prodotto sono disponibili in versione digitale (PDF) su <https://www.bergstromspain.com/>

La vendita e la garanzia sono disciplinate dalla versione più aggiornata delle nostre condizioni generali di vendita, pubblicata sul nostro sito web <https://www.bergstromspain.com/>

Spiegazione dei simboli



- **Avvertenza:** Avvertenza di sicurezza riguardo a una situazione che, se non venisse evitata, potrebbe provocare gravi lesioni anche mortali.



- **Pericolo:** Rischio di taglio. Segnala una situazione che potrebbe provocare una lesione da taglio.



- **Pericolo:** Rischio di folgorazione. Segnala una situazione che potrebbe provocare una lesione da folgorazione.



- **Avviso:** Avviso di sicurezza riguardo a una situazione che, se non venisse evitata, potrebbe provocare danni all'impianto o ad altri materiali.



- **Informazioni:** Ulteriori informazioni sull'installazione o sulla gestione del prodotto.



- **Fragile:** Indica una situazione in cui si deve procedere con attenzione per non causare danni all'impianto e ad altri materiali.



Esclusione di responsabilità

- **Dirna Bergstrom** declina ogni responsabilità per eventuali danni causati dai casi seguenti:
 - Danni al prodotto provocati da sollecitazioni meccaniche e sovratensioni.
 - Modifiche effettuate sull'impianto senza esplicita autorizzazione del costruttore.
 - Uso l'impianto per fini diversi da quelli riportati in questo documento.
 - Movimentazione o installazione errata dell'impianto.

- È vietato qualsiasi intervento sui circuiti del gas refrigerante senza esplicita autorizzazione del costruttore.



Avvertenze durante il montaggio

- L'installazione, la riparazione e la manutenzione di questo impianto di aria condizionata possono essere eseguite esclusivamente da personale tecnico in possesso della formazione necessaria nel campo dell'aria condizionata per veicoli, eventuali pericoli e norme applicabili.
- Leggere attentamente le istruzioni di montaggio prima di iniziare l'installazione dell'impianto. Durante l'installazione, seguire alla lettera le istruzioni indicate.
- Quando si installa l'impianto di aria condizionata sul tettuccio, bisogna proteggere la parte superiore della cabina con uno straccio o una coperta per evitare eventuali graffi. Per l'installazione del **INTEGRAL POWER**, tenere presente che normalmente le cabine munite di oblò dispongono di una struttura abbastanza solida per sostenere il peso dell'impianto. Tuttavia, se così non fosse e se fosse necessario tagliare il tettuccio, o se in presenza di oblò la struttura non fosse abbastanza rigida (se fosse di fibra, plastica, ecc.), è responsabilità dell'installatore decidere se occorre rinforzare il tettuccio per evitare qualsiasi deformazione, rottura o penetrazione d'acqua, ecc., prendendo le misure necessarie per evitarlo.
- Disinserire la chiave di avviamento prima di iniziare l'installazione dell'impianto.
- Disinserire la batteria del veicolo prima di cominciare l'installazione dell'impianto.
- Installare **INTEGRAL POWER** in modo sicuro per evitare cadute.
- Usare gli attrezzi più adatti per ogni operazione.
- Durante l'installazione, assicurare la connessione dei componenti elettrici, verificandone il corretto inserimento.
- Se nell'installazione dell'impianto i cablaggi attraversano pareti con bordi affilati, proteggere adeguatamente i cavi con guaine o passacavi per evitarne il danneggiamento.

- Se durante l'installazione l'impianto viene inclinato o si ribalta la cabina con l'impianto installato, prima di avviarlo occorre attendere almeno 60 minuti dal momento in cui l'impianto è di nuovo in posizione orizzontale.
- Dispositivo precaricato con gas refrigerante R-134a.



- **Avvertenza importante:** Qualsiasi modifica dei sistemi ROPS / FOPS, come l'esecuzione di saldature o perforazioni nelle parti strutturali, inciderà negativamente sulla capacità di tali sistemi ROPS / FOPS di fornire la protezione richiesta. L'installazione di questo prodotto può incidere sui sistemi ROPS / FOPS.

Rivolgersi al proprio rivenditore di fiducia per verificare la compatibilità prima di effettuare modifiche o riparazioni. Altrimenti si potrebbe essere annullata la certificazione ROPS / FOPS. Il costruttore dell'impianto di aria condizionata montato sul tettuccio declina ogni responsabilità.



Attrezzi necessari per il montaggio

- Kit di chiavi Torx.
- Kit di chiavi Allen.
- Chiave fissa 10.
- Forbici.
- Flessometro.
- Set chiavi a cricchetto - bocca Ø 10.
- Cacciavite stella / cacciavite.
- Sega circolare Ø 35.
- Trapano - bocca Ø 7.
- Sega a svolgere.



Documenti correlati

- Guida rapida: 1002455105
- Manuale dell'utente: 1002192411
- Elenco dei pezzi di ricambio: 1003714494
- Diagnosi dei guasti: 1002192414

Dirna Bergstrom dichiara che l'impianto **INTEGRAL POWER** soddisfa i requisiti delle seguenti direttive CE e che sono state applicate le norme e le specifiche tecniche armonizzate riportate di seguito:

- Direttiva CE 2014/53/EU
- Direttiva CE 2011/65/EU
- Direttiva CE 2014/30/EU



Nota bene: L'impianto **Integral Power II** è dotato di 4 golfari saldati ai lati della base per agevolare il sollevamento in sicurezza mediante un mezzo meccanico.

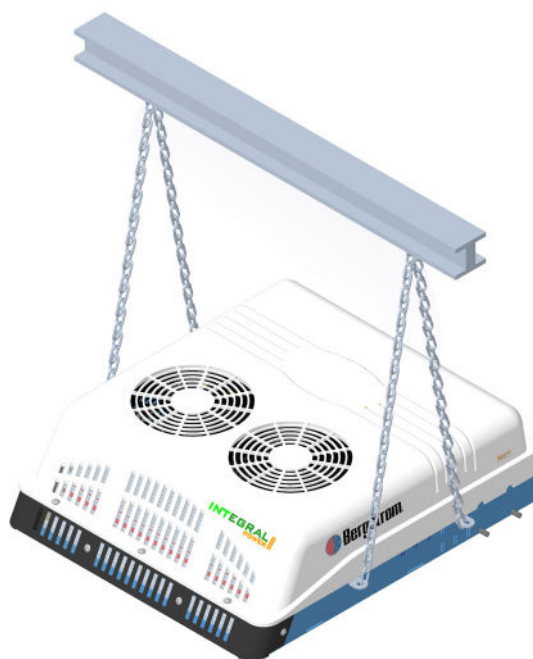
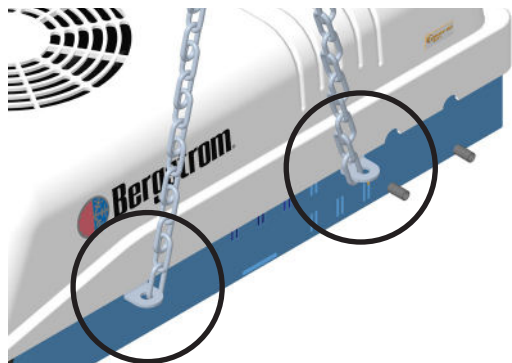

1 Posizionare l'impianto **Integral Power II** sul tettuccio, tenendo conto che la posizione finale deve coincidere con il frontalino in dotazione facendo in modo che sia livellato sulla superficie.

2 Una volta determinata la posizione, rimuovere l'involucro e segnare i (6) fori (Y) e quindi fare coincidere i (4) fori della dima con i (4) fori posteriori del tettuccio (figura 3).

Tenere conto della freccia che indica il senso di marcia.

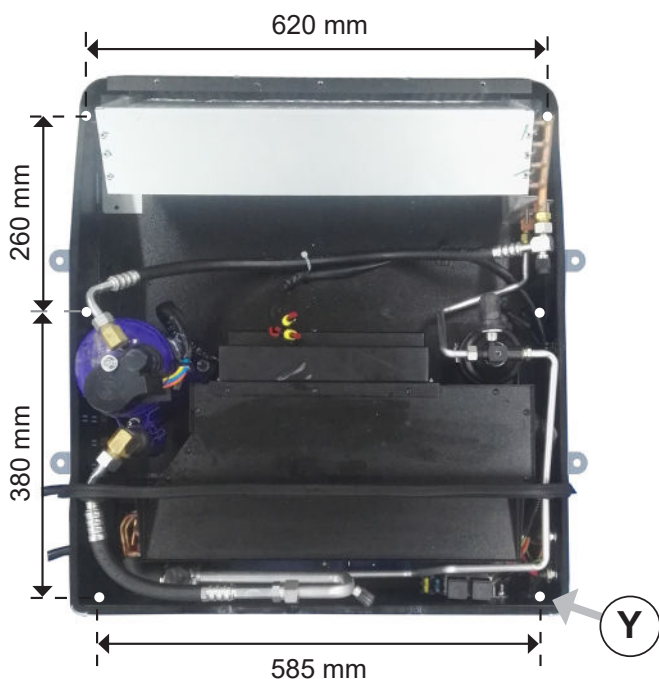
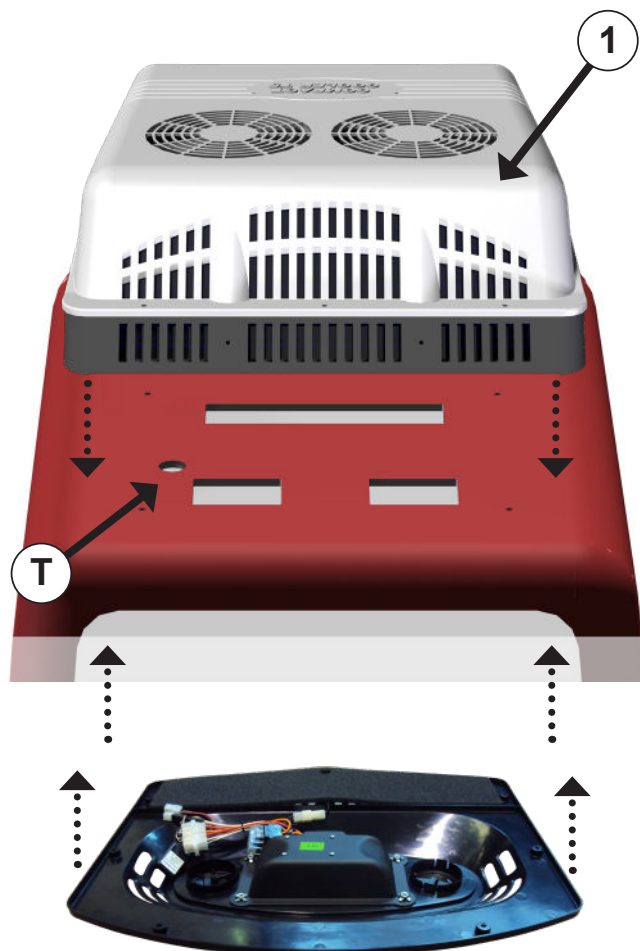

3 Segnare i tagli e i fori e quindi eseguirli (proteggere i bordi tagliati con antiossidante).

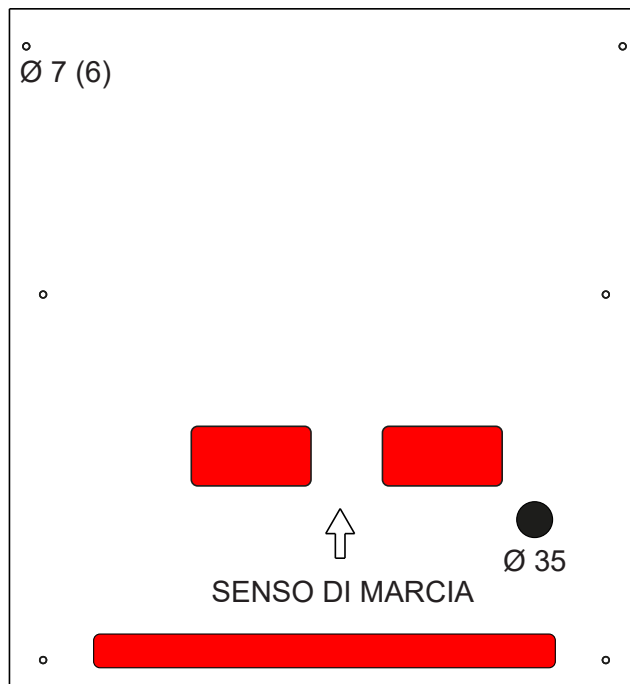

4 Montare la guarnizione di chiusura, le guarnizioni laterali e quella frontale nella parte interna, come illustrato nella figura.

a	Guarnizione di chiusura
b	Guarnizioni laterali
c	Guarnizione frontale

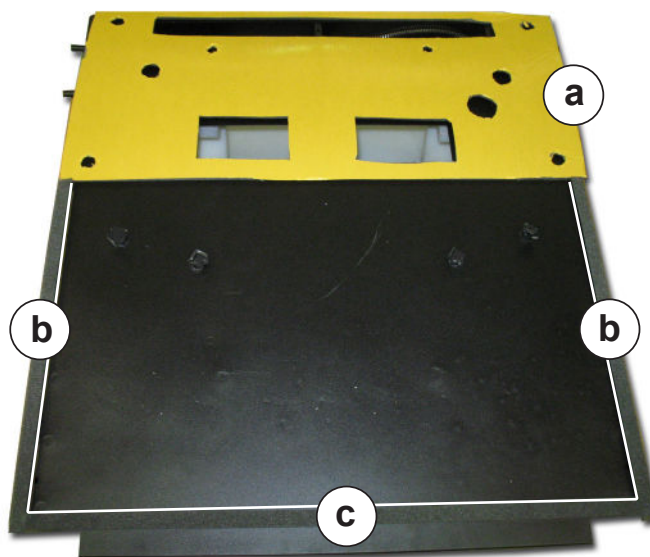

5 Far passare il cablaggio nell'apposito foro (T) sul tettuccio (figura 1). Fissare l'**Integral Power** (A) con (6) boccole da 13 mm, le rondelle di gomma e (6) viti M6/100x40 (B) e i dadi M6/100.

 **Nota bene:** Verificare la tenuta dell'insieme sul tettuccio per evitare eventuali infiltrazioni d'acqua.

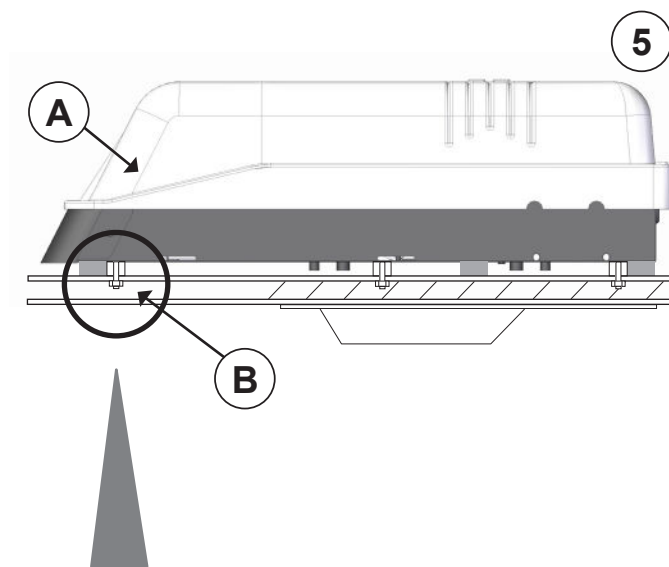

6a Inserire le rondelle di gomma per evitare l'infiltrazione dell'acqua.

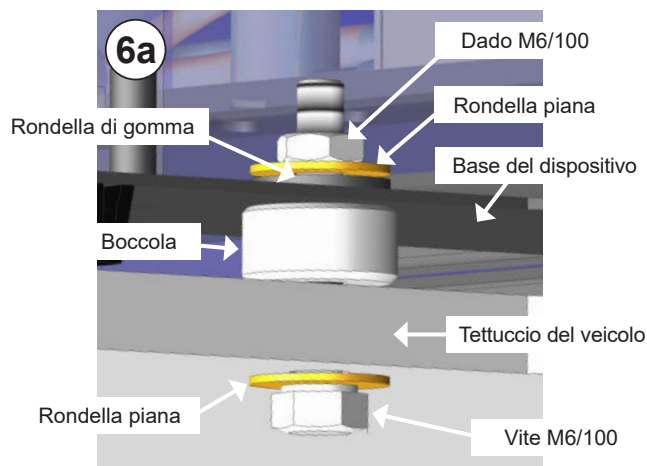

6b Montare sull'impianto i tubi in PVC Ø 9 x Ø 13 in dotazione alla lunghezza richiesta.

 **Attenzione:** montare valvole di drenaggio alla fine dei tubi in PVC per agevolare il drenaggio dell'acqua.

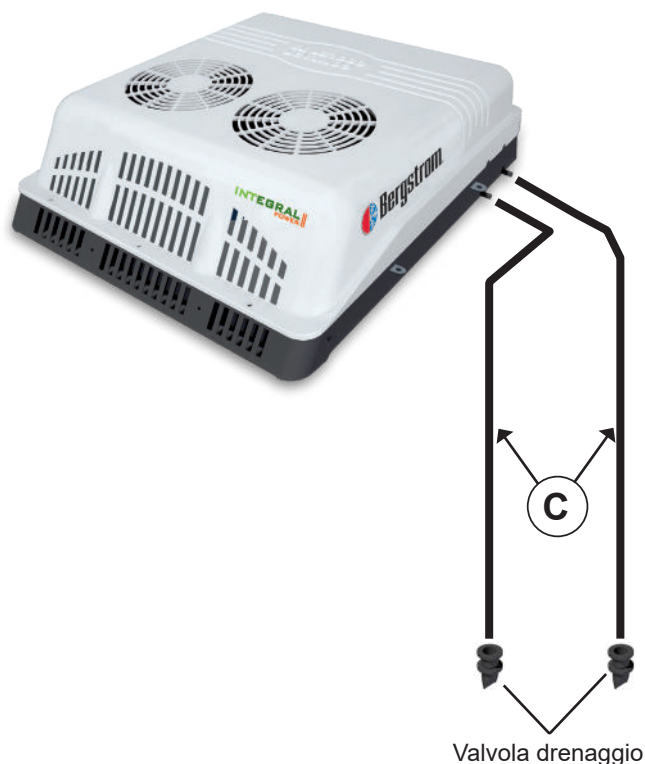

Cablaggio di connessione all'alternatore per il funzionamento dell'impianto con motore acceso

 **Attenzione:** Il cablaggio si deve installare in tutti i veicoli in cui l'impianto deve funzionare con il motore acceso.

7 Far passare il cablaggio d'eccitazione dall'interno o dall'esterno del veicolo a seconda della convenienza e montare il frontalino con le viti per lamiera in dotazione. Collegare gli interruttori come indicato.

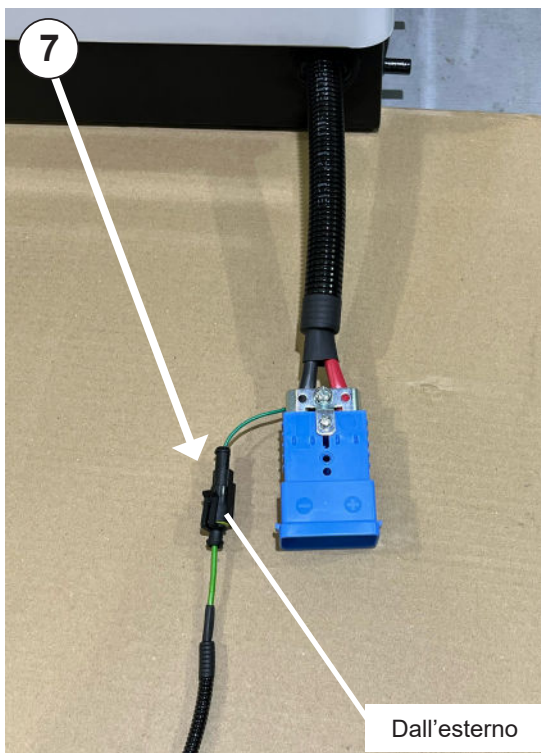
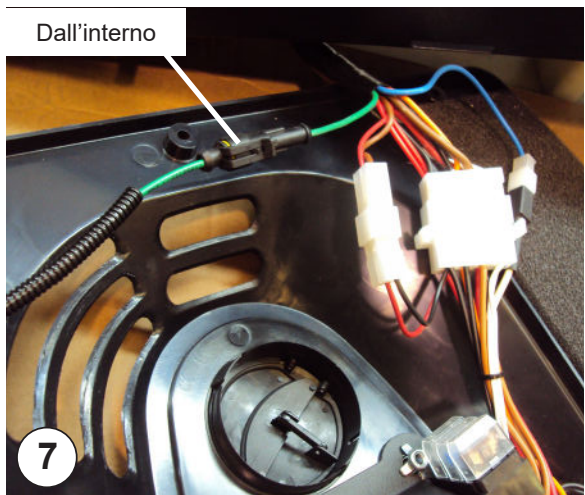

8

Collegare l'altra estremità del cablaggio in posizione (+) solo (+) con il motore acceso o tramite (+) chiave di accensione.

9

Collegare il cavo di alimentazione alla parte posteriore dell'apparecchiatura.

Condurre il cablaggio di alimentazione alla batteria del veicolo.

Nota bene: Per collegare i cablaggi, lasciare una distanza adeguata per evitarne la rottura a causa dei movimenti del veicolo.

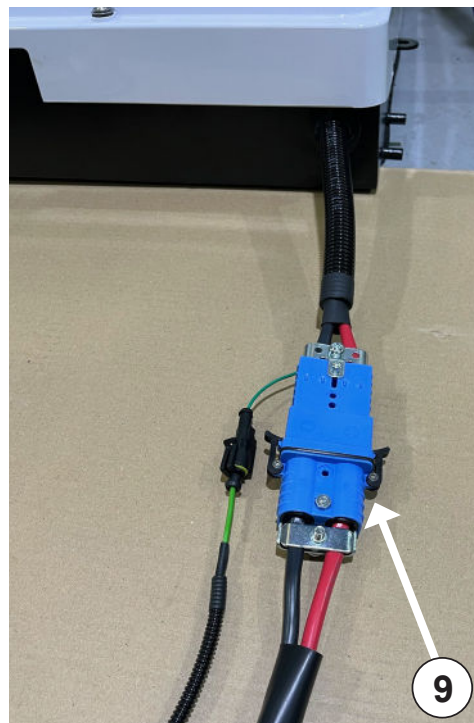

10

Per i veicoli la cui cabina è ribaltabile, sono stati inseriti 2 adesivi che ricordano la necessità di disinserire il cablaggio di alimentazione dell'apparecchiatura prima di ribaltare la cabina.

Posizionare gli adesivi accanto al meccanismo di ribaltamento della cabina e al collegamento del cablaggio di alimentazione.



Attenzione: per i veicoli che richiedono una lunghezza maggiore del cablaggio di alimentazione o la cui cabina è ribaltabile, è disponibile una prolunga opzionale di 3 metri, riferimento: 1003713621.



Nota bene: Per l'avviamento, vedi il Manuale dell'utente (1002192411).

Cablaggio elettrico

Az	Blu
N	Nero
R	Rosso
V	Verde
B	Bianco
A	Giallo
Na	Arancione
M	Marrone

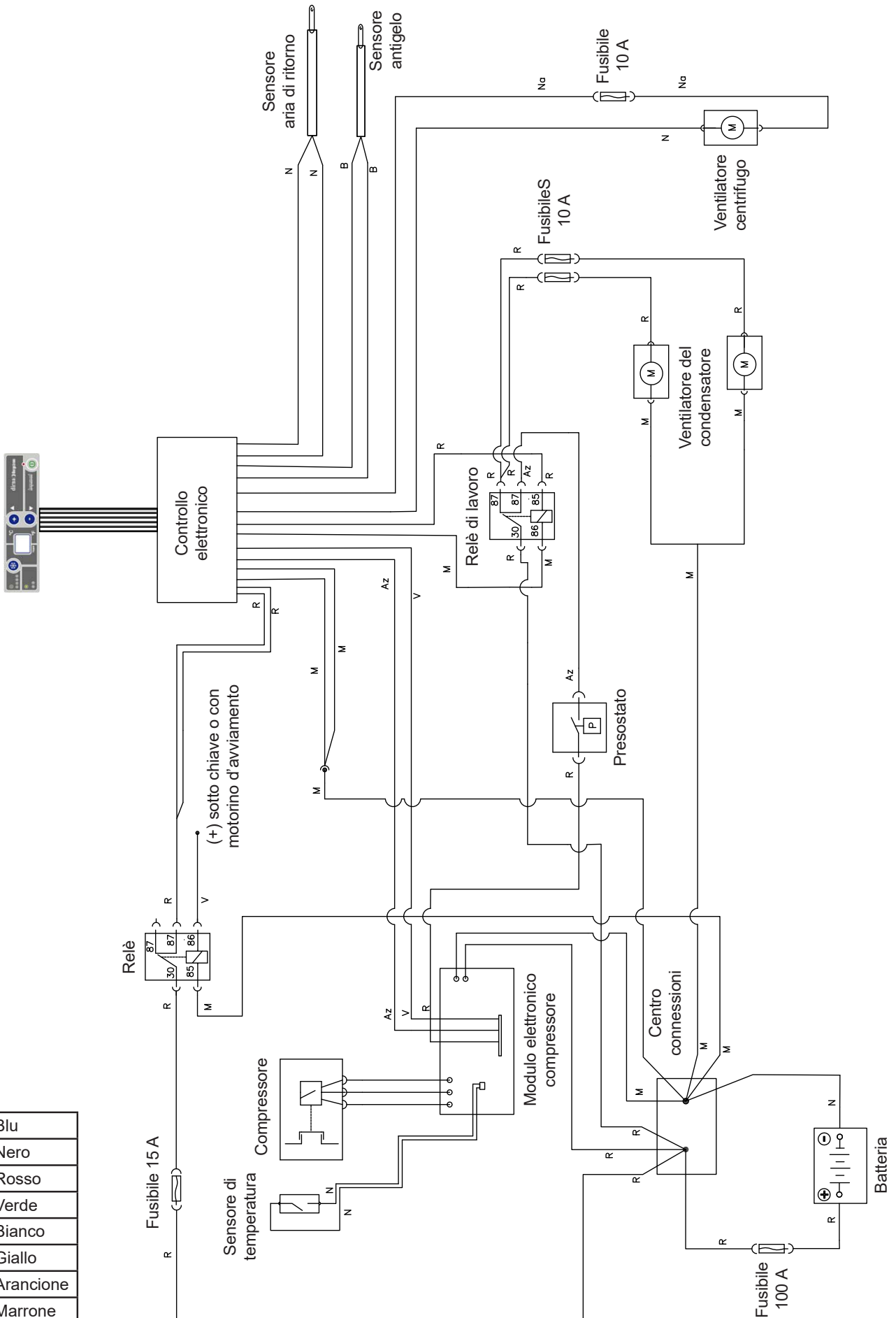

A series of horizontal dotted lines spanning the width of the page, providing a template for handwritten notes or calculations.



Francisco Alonso, 11A
28806 Alcalá de Henares, Madrid
SPAIN

Ed:	26/06/2024
Md:	

Contact	Phone	Fax	E-Mail
Sales (Ventas Internacional)	+34 91 8770510	+34 91 8771158	sales@dirna.bergstrominc.com
Comercial Nacional	+34 91 8775841	+34 91 8836321	ventas@dirna.bergstrominc.com
Orders & Deliveries (Logística internacional)	+34 91 8775846	+34 91 8771158	export@dirna.bergstrominc.com
Orders & Deliveries (Logística nacional)	+34 91 8775840	+34 91 8836321	comercial@dirna.bergstrominc.com
Technical Assistance (Internacional)	+49 511 86679681	+49 511 86679710	technicalassistance@dirna.bergstrominc.com
Technical Assistance (Nacional)	+34 91 8775845	+34 91 883 6321	asistenciatecnica@dirna.bergstrominc.com

www.bergstromspain.com

	ATENCIÓN:	Bergstrom se reserva el derecho de efectuar modificaciones en cualquier momento de los datos contenidos en esta publicación, por razones técnicas o comerciales.
	NOTE:	<i>For technical and commercial reasons, Bergstrom reserves the right to change the data contained in this brochure.</i>
	ATTENTION:	Bergstrom se réserve le droit d'effectuer à tout moment des modifications des données reprises sur cette publication, pour des raisons techniques ou commerciales.
	HIWEIS:	<i>Bergstrom behält sich vor, aus technischen oder kaufmännischen Gründen jederzeit Änderungen der Angaben dieser Veröffentlichung vorzunehmen.</i>
	ATTENZIONE:	Bergstrom si riserva il diritto di effettuare modifiche in qualsiasi momento ai dati contenuti in questa pubblicazione, per motivi tecnici o commerciali.